



iH600 Pump

iH Series Dry Pumping Systems

Trillium is the market leader in supplying refurbished Edwards iH series dry pumping systems. Whether it's the purchase of additional systems or the servicing of your existing product, Trillium is equipped with the core pump stacks, machined parts inventory and technical capability to deliver OEM level quality. In addition, Trillium's aesthetic renewal program is available to match the appearance of the product to its performance.

Available in a range of 3 Phase voltages, the iH series of pumps are ideally suited for applications that benefit from higher operating temperatures. Like other Edwards dry pumps, the iH series can be easily interfaced to process tools and have extensive on board monitoring features, including a sophisticated purge gas system.

COMPETITIVE

Attractive Pricing
Immediate Availability

HIGH QUALITY

Full Engineering Department
ISO-9001 Certified

COMPATIBLE

Fully Interchangeable
with Stokes Product

WELL SUPPORTED

After Sale Service & Spares
From 3 US Service Centers

Contact Trillium Today | trilliumus.com | 800.453.1340



iH Series Dry Pumps

PERFORMANCE SPECIFICATIONS

| Specifications | iH80 | iH600 | iH1000 | iH1800 |
|-------------------|---|-------------|-------------|------------|
| Displacement | 61 CFM | 353 CFM | 580 CFM | 1060 CFM |
| Ultimate Pressure | 7.5 mTorr | 1 mTorr | 1 mTorr | .75 mTorr |
| Motor Rating | 3.5 kW | 3.5 kW | 3.5 kW | 3.5 kW |
| Motor Power | 230/460V 3Ph 60Hz (other voltages available upon request) | | | |
| Oil Capacity | .7 liters | 1.43 liters | 1.43 liters | 1.6 liters |
| Weight | 240 kg | 415 kg | 430 kg | 502kg |
| Inlet Size | ISO63 | ISO100 | ISO100 | ISO160 |
| Outlet Size | NW40 | NW40 | NW40 | NW40 |



iH80



iH600



iH1000



iH1800

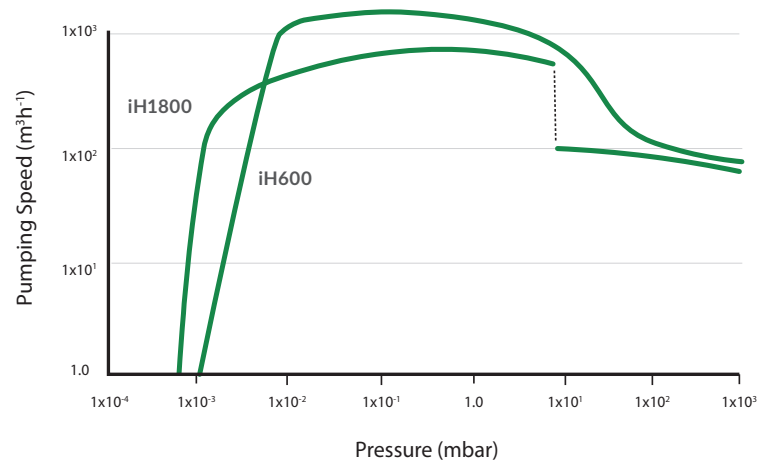
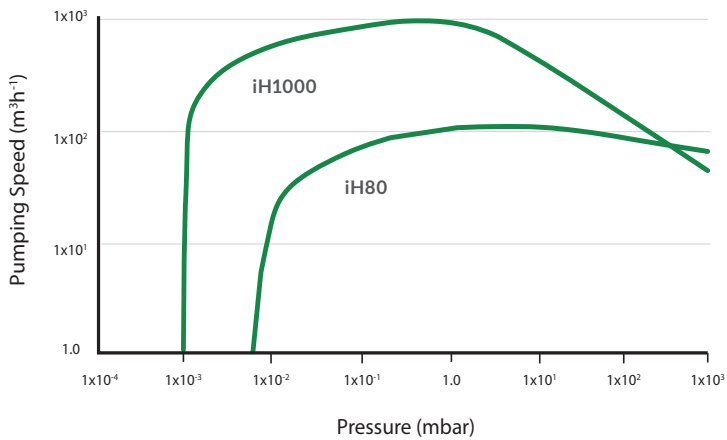

Contact Trillium Today | trilliumus.com | 800.453.1340

iH1000 Pump



DIMENSIONAL DATA

| Dimension | iH80 | iH600 | iH1000 | iH1800 |
|-----------|-------|-------|--------|--------|
| A | 661mm | 661mm | 661mm | 661mm |
| B | 322mm | 309mm | 314mm | 325mm |
| C | 159mm | 163mm | 163mm | 198mm |
| D | 302mm | 302mm | 302mm | 302mm |
| E | 293mm | 466mm | 481mm | 528mm |

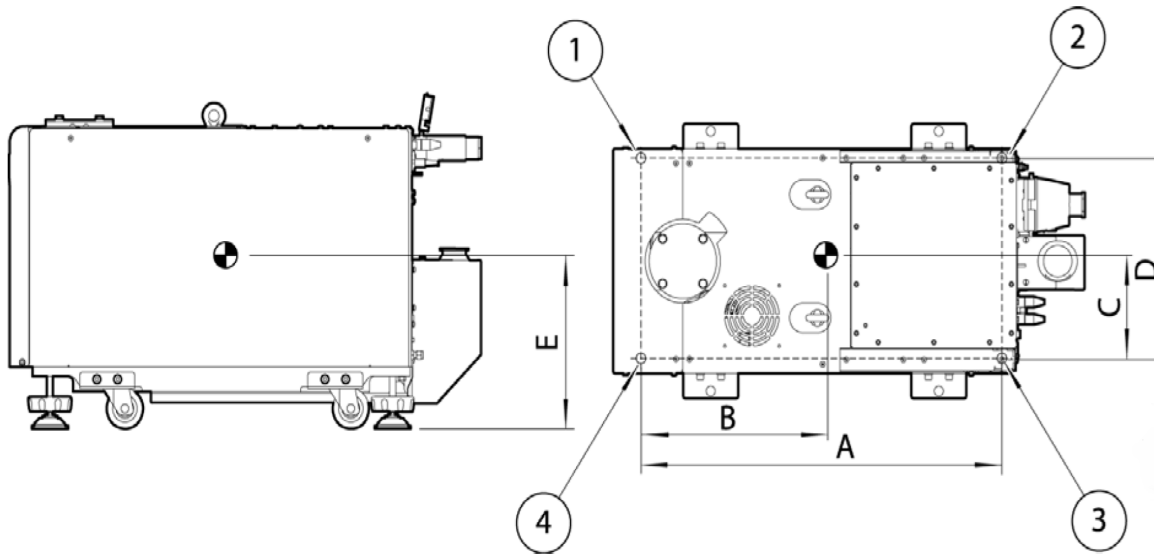

ACCESSORIES



Silencer

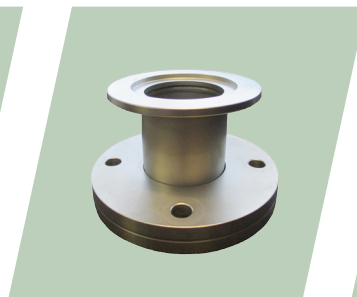

Inlet Adapter



iTim



Valve



NEW & REFURBISHED SYSTEMS | SPARE PARTS | SERVICE

Trillium is your single source for expert Service, Exchange, New & Refurbished Systems and Parts. With 3 nationwide locations, an in-house machine shop, and ready-to-ship inventory, customers love our short lead times and competitive costs. Plus, our ISO-9001 certified quality system and decades of expertise allow us to deliver top-notch products and services every time. Clients find us easy to do business with due to our sophisticated back office systems, customized weekly status reports, flexible pricing options, and our popular equipment buy-back program.



Expert Service, Exchange & Refurbished Units

Other Pumping Systems



Factory Service, Parts & Support

Temperature Control Units



Refurbished Systems & Field Service

New Abatement Systems

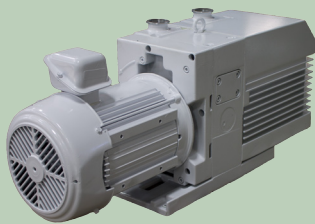

Rotary Vane Pumps



Cryo Pumps



Helium Compressors

3 Nationwide Locations to Serve You

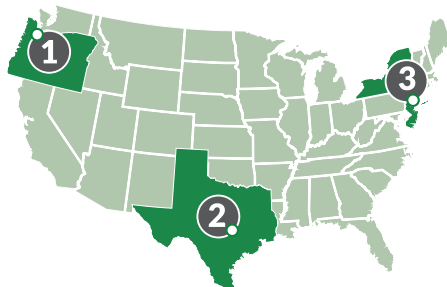

TRILLIUM LOCATIONS

- 1 Portland, OR
- 2 Austin, TX
- 3 Metro NY/NJ



Contact Trillium Today | trilliumus.com | 800.453.1340