

HELIX

Cryo-Torr® Pump Installation, Operation and Maintenance Instructions

The information in this document is believed to be accurate and reliable. However, Helix Technology Corporation, cannot accept any financial or other responsibilities that may result from the use of this information. No warranties are granted or extended by this document.

Helix Technology Corporation reserves the right to change any or all information contained herein without prior written notice. Revisions may be issued at the time of such changes and/or deletions.

Any duplication of this manual or any of its parts without expressed written permission from Helix Technology Corporation is strictly prohibited.

Any correspondence regarding this document should be forwarded to:

Helix Technology Corporation
Mansfield Corporate Center
Nine Hampshire Street
Mansfield, Massachusetts 02048-9171 U.S.A.

Telephone: (508) 337-5000
FAX: (508) 337-5464

The following Helix Technology Corporation trademarks and service marks may appear in this document:

Conductron™	Convectron®	Cryodyne®	Cryogen®
Cryogenerator®	Cryo-Torr®	CTI-Cryogenics®	FastRegen™
GOLDLink®	Granville-Phillips™	GUTS®	Helix Technology.. Your Vacuum Connection SM
Helix®	Micro-Ion®	Mini-Ion™	On-Board®
RetroEase®	RetroFast®	Stabil-1®	Stabil-Ion®
ThinLine™	TurboPlus®	Vacuum Assurance SM	

All other trademarks or registered trademarks are the property of their respective holders.

Table of Contents

Figures

Tables

Cryopump Safety

Introduction	S-1
Warnings	S-1
Toxic, Corrosive, Dangerous Gases, or Liquids	S-1
Flammable or Explosive Gases	S-1
High Voltage	S-2
High Gas Pressure	S-2
Cautions	S-2
Cryopump Oxygen Procedures	S-2

Section 1 - Cryo-Torr Cryopump Description

Introduction	1-1
Installation, Operation, and Service Instructions	1-1
Specifications	1-4
Theory of Operation	1-15
Cold Head	1-15
Vacuum Vessel and Arrays	1-15
Compressor Gas and Oil Flows	1-17
Cryo-Torr Interface	1-17

Section 2 - Installation

Introduction	2-1
Installation	2-2
Vent Pipe Connection	2-2
Roughing Pump Connection	2-2
Purge Gas Connection	2-3
Helium Return and Supply Line Connections	2-5
Power Cable Connection	2-5
Crossover Pressure Calculations	2-5
Optimizing Crossover Pressure	2-6
Cryo-Torr Cryopump Capacity Calculations	2-7
Crossover Cycle Calculations	2-8
Cryopump Start-up Procedure	2-8
Cryopump Shutdown Procedure	2-9
Cryopump Storage	2-10

Section 3 - Regeneration

Introduction	3-1
When to Regenerate	3-1
Assisted Regeneration	3-2

Section 4 - Troubleshooting

Troubleshooting the Cryopump	4-1
Technical Inquiries	4-1

Section 5 - Maintenance Procedures

Helium Circuit Decontamination	5-1
Cryo-Torr Cryopump Decontamination Procedures	5-1
Cleaning the Cryo-Torr Cryopump	5-3

Appendix A - Customer Support Information

Customer Support Center Locations	A-1
Guaranteed Up-Time Support (GUTS)	A-1
Product Information	A-1
E-mail	A-1

Index

Figures

Figure 1-1: Cryo-Torr Pumps	1-2
Figure 1-2: Cryo-Torr Pumps	1-3
Figure 1-3: Cutaway View of a Typical Cryo-Torr Pump	1-16
Figure 1-4: Cryo-Torr Interface	1-17
Figure 1-5: Typical Cryo-Torr System with 9000 Series Compressor	1-18
Figure 1-6: Typical Cryo-Torr System with 8200 Compressor	1-19
Figure 1-7: Typical Cryo-Torr System with 8600 Compressor	1-20
Figure 2-1: Block Diagram for Cryo-Torr System Installation	2-1
Figure 2-2: Gas/Electrical Components on a Typical Cryo-Torr Cryopump	2-4

Tables

Table 1-1: Cryo-Torr 4F Cryopump Specifications	1-4
Table 1-2: Cryo-Torr 8 Cryopump Specifications	1-5
Table 1-3: Cryo-Torr 8F Cryopump Specifications	1-6
Table 1-4: Cryo-Torr 10 Cryopump Specifications	1-7
Table 1-5: Cryo-Torr 10F Cryopump Specifications	1-8
Table 1-6: Cryo-Torr 250F Standard Cryopump Specifications	1-9
Table 1-7: Cryo-Torr 250FH High Capacity Cryopump Specifications	1-10
Table 1-8: Cryo-Torr 400 Standard Capacity Cryopump Specifications	1-11
Table 1-9: Cryo-Torr 400 High Capacity Cryopump Specifications	1-12
Table 1-10: Cryo-Torr 500 Cryopump Specifications	1-13
Table 1-11: Cryo-Torr 20HP Cryopump Specifications	1-14
Table 2-1: Crossover Values	2-6
Table 2-2: Condensable Gases Capacity (Argon, Nitrogen, Oxygen, etc.)	2-7
Table 3-1: Required Accessories for Assisted Regeneration	3-2
Table 4-1: Troubleshooting Procedures	4-2
Table 5-1: Indium Gasket Screw Torque Specifications	5-4

Cryopump Safety

Introduction

Cryo-Torr products have been designed to provide extremely safe and dependable operation when properly used. Safety precautions must be observed during normal operation and when servicing the Cryo-Torr system.

NOTE: Read this manual and follow these safety guidelines before installing, operating, or servicing Cryo-Torr products.

Warnings

A warning describes safety hazards or unsafe practices which could result in personal injury or loss of life. A warning message is accompanied by a symbol as described in the following paragraphs and is also surrounded by a box to attract your attention.

Toxic, Corrosive, Dangerous Gases, or Liquids



Toxic, corrosive, dangerous gases, or liquids which may be present in an Cryo-Torr product could cause severe injury upon contact. Make sure the following precautions are taken when handling toxic, corrosive, or dangerous gases.



1. Always vent toxic, corrosive, dangerous gases, or liquids to a safe location using an inert purge gas.
2. Clearly identify toxic, corrosive, dangerous gases, or liquids on containers used to store or ship equipment after such exposure.

Flammable or Explosive Gases



Flammable or explosive gases which may be present in an Cryo-Torr product could cause severe injury if ignited. Make sure the following precautions are taken when handling flammable or explosive gases:



1. Always vent flammable or explosive gases to a safe location using an inert purge gas.
2. Do not install a hot filament type vacuum gauge on the high vacuum side of the isolation valve. This could be an ignition source of flammable gases in Cryo-Torr products.

High Voltage

High voltage electric shock can cause severe injury or loss of life. Take the following precautions to prevent high voltage risks:



1. Disconnect the high vacuum pump system from all power sources before making electrical connections between system components or before performing troubleshooting and maintenance procedures.

High Gas Pressure

High gas pressure may be present within high vacuum pump systems and can cause severe injury from propelled particles or parts.



1. Do not modify or remove the pressure relief valves, either on the Cryo-Torr pump or within the helium compressor.
2. Always depressurize the adsorber to atmospheric pressure before disposing.
3. Always bleed the helium charge down to atmospheric pressure before servicing or disassembling the self sealing couplings.

Cautions

A caution describes safety hazards or unsafe practices which could result in equipment damage.

Cryopump Oxygen Procedures



WARNING

Combustion supported by oxygen in the cryopump could cause severe injury when oxygen is used as a process gas. Special precautions described in the following text should be taken.

When oxygen is used as a process gas, the following precautions should be taken:

1. Insure that there are no sources of ignition (e.g. hot filament vacuum gauges) on the cryopump side of the high vacuum valve operating during the warming or venting of the cryopump.

2. Perform inert gas purge regeneration cycles at flow rates recommended for cryopumps.
3. Regenerate as frequently as practical to minimize the amount of oxidizer present in the cryopump.
4. It is standard practice in the vacuum industry that any system exposed to richer-than-air oxygen levels should be prepared for oxygen service per the manufacturer's recommendations, including use of oxygen service lubricating oils in roughing pumps.

WARNING



Explosion occurring from ozone in the cryopump could cause severe injury. Ozone can be present as a by product of oxygen processes. If ozone is present, special precautions described in the following text must be taken.

Ozone may be unknowingly produced in an ionizing process (e.g. sputtering, etching, glow discharge). Explosive conditions may exist if ozone is present, especially during the warming of the cryopump. Signs of ozone's presence are:

1. Crackling, popping sounds (as in electrical arcing) occurring within the first few minutes of a regeneration cycle.
2. Gas venting from the cryopump during regeneration may have a pungent smell, similar to that present in an arc welding operation or after an electrical storm.

NOTE: *A change in process may increase the amount of ozone present.*

If ozone is present, the following precautions must be taken:

1. All of the above oxygen precautions must be followed. The required regeneration frequency is dependent upon flow and process conditions. Daily regeneration may be required. Call CTI-CRYOGENICS for assistance.
2. Reduce the oxygen mixture to the lowest level the process will allow.

Section 1 - Cryo-Torr Cryopump Description

Introduction

Cryo-Torr pumps, shown in [Figure 1-1](#) and [Figure 1-2](#), are one of the two major components that make up the Cryo-Torr Pumping System. The second component is the Compressor. Instructions for the compressor are contained in each compressor manual.

The Cryo-Torr Pump provides fast, clean pumping of all gases in the 10^{-3} to 10^{-9} Torr range. The cryopump operates on the principle that gases can be condensed and held at extremely low vapor pressures, achieving high speeds and throughputs, as described in [Table 1-1](#) - [Table 1-11](#).

Your Cryo-Torr Pump is a highly-reliable and rugged unit that requires a minimum of servicing. Since the cryopump exposes no moving parts, operating fluids, or backing pumps to the vacuum, the possibility of system or process contamination from the cryopump itself is eliminated.

Installation, Operation, and Service Instructions

Installation, Operation and Maintenance Instructions for your Cryo-Torr vacuum pump provides easily accessible information. All personnel with installation, operation, and servicing responsibilities should become familiar with the contents of these instructions to ensure safe, reliable cryopump performance.

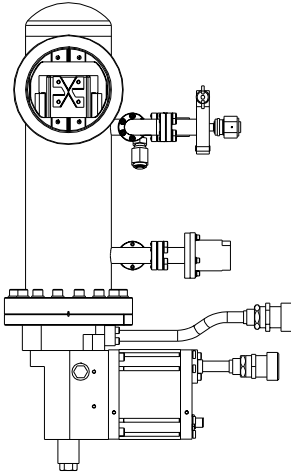

CRYO-TORR 4F

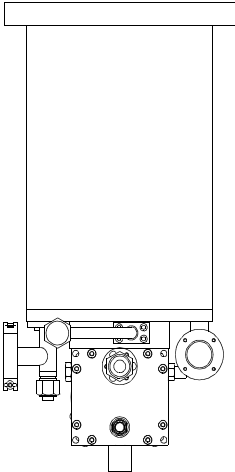

CRYO-TORR 8

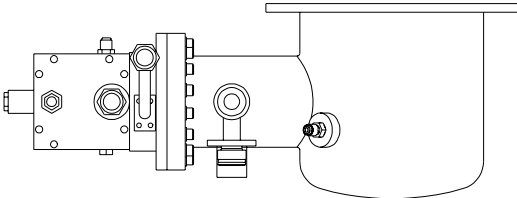

CRYO-TORR 8F

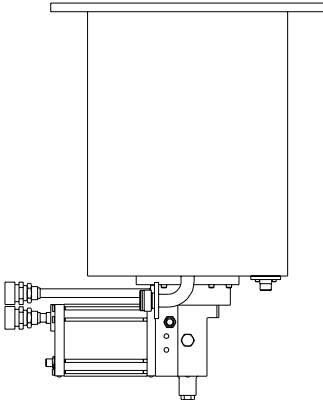

CRYO-TORR 10

Figure 1-1: Cryo-Torr Pumps

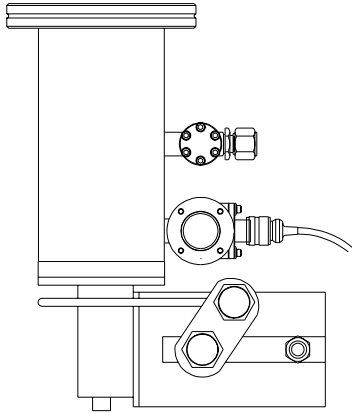

CRYO-TORR 100

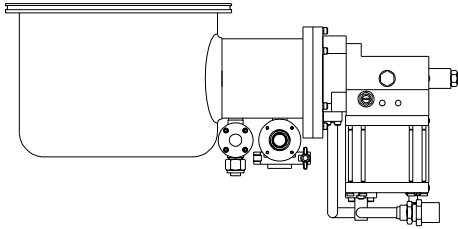

CRYO-TORR 250F

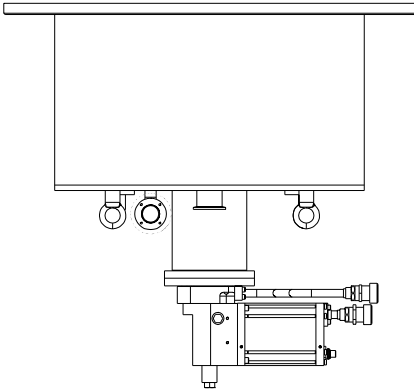

CRYO-TORR 20HP

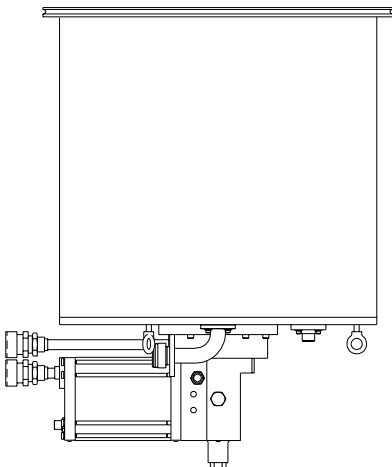

CRYO-TORR 400

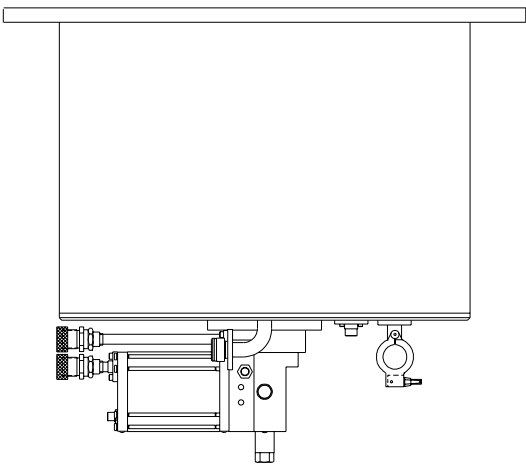

CRYO-TORR 500

Figure 1-2: Cryo-Torr Pumps

Specifications

Table 1-1: Cryo-Torr 4F Cryopump Specifications

Parameter	Specifications
Rough Pump Connection	NW 25 ISO KF
Integrated Hardware	Second Stage Diode
Pumping Speeds:	
Water	1100 liters/sec
Air	370 liters/sec
Hydrogen	370 liters/sec
Argon	310 liters/sec
Argon Throughput	700 scc/min. (9 Torr liters/second)
Capacity:	
Argon	210 std. liters
Hydrogen	3 std. liters @ 5×10^{-6} Torr
Crossover	100 Torr-liters
Cooldown Time	
60 Hz	75 min.
50 Hz	90 min.
Dimensions	Refer to Installation/Interface drawing
Weight	37 lbs. (17 kg)

Table 1-2: Cryo-Torr 8 Cryopump Specifications

Parameter	Specifications
Rough Pump Connection	NW 25 ISO KF
Integrated Hardware	Second Stage Diode
Pumping Speeds:	
Water	4000 liters/sec
Air	1500 liters/sec
Hydrogen	2500 liters/sec
Argon	1200 liters/sec
Argon Throughput	700 scc/min. (9 Torr liters/second)
Capacity:	
Argon	1000 std. liters
Hydrogen	17 std. liters @ 5×10^{-6} Torr
Crossover	150 Torr-liters
Cooldown Time	
60 Hz	90 min.
50 Hz	110 min.
Dimensions	Refer to Installation/Interface drawing
Weight	45 lbs. (20 kg)

Table 1-3: Cryo-Torr 8F Cryopump Specifications

Parameter	Specifications
Rough Pump Connection	NW 25 ISO KF
Integrated Hardware	Second Stage Diode
Pumping Speeds:	
Water	4000 liters/sec
Air	1500 liters/sec
Hydrogen	2200 liters/sec
Argon	1200 liters/sec
Argon Throughput	700 scc/min. (8.9 Torr liters/second)
Capacity:	
Argon	1000 std. liters
Hydrogen	8 std. liters @ 5×10^{-6} Torr
Crossover	150 Torr-liters
Cooldown Time	
60 Hz	90 min.
50 Hz	110 min.
Dimensions	Refer to Installation/Interface drawing
Weight	42 lbs. (19 kg)

Table 1-4: Cryo-Torr 10 Cryopump Specifications

Parameter	Specifications
Rough Pump Connection	NW 25 ISO KF
Integrated Hardware	Second Stage Diode
Pumping Speeds:	
Water	9000 liters/sec
Air	3000 liters/sec
Hydrogen	5000 liters/sec
Argon	2500 liters/sec
Argon Throughput	1500 scc/min. (19 Torr liters/second)
Capacity:	
Argon	2000 std. liters
Hydrogen	24 std. liters @ 5×10^{-6} Torr
Crossover	300 Torr-liters
Cooldown Time	
60 Hz	100 min.
50 Hz	120 min.
Dimensions	Refer to Installation/Interface drawing
Weight	85 lbs. (39 kg)

Table 1-5: Cryo-Torr 10F Cryopump Specifications

Parameter	Specifications
Rough Pump Connection	NW 25 ISO KF
Integrated Hardware	Second Stage Diode
Pumping Speeds:	
Water	9500 liters/sec
Air	3600 liters/sec
Hydrogen	6000 liters/sec
Argon	3000 liters/sec
Argon Throughput	1500 scc/min. (19 Torr liters/second)
Capacity:	
Argon	2000 std. liters
Hydrogen	24 std. liters @ 5×10^{-6} Torr
Crossover	300 Torr-liters
Cooldown Time	
60 Hz	100 min.
50 Hz	120 min.
Dimensions	Refer to Installation/Interface drawing
Weight	90 lbs. (41 kg)

Table 1-6: Cryo-Torr 250F Standard Cryopump Specifications

Parameter	Specifications
Rough Pump Connection	NW 25 ISO KF
Integrated Hardware	Second Stage Diode
Pumping Speeds:	
Water	6500 liters/sec
Air	2200 liters/sec
Hydrogen	3200 liters/sec
Argon	1800 liters/sec
Argon Throughput	700 scc/min.
Capacity:	
Argon	1000 std.
Hydrogen	16 std. liters @ 5×10^{-6} Torr
Crossover	150 Torr-liters
Cooldown Time	
60 Hz	100 min.
50 Hz	120 min.
Dimensions	Refer to Installation/Interface drawing
Weight	48 lbs. (22 kg)

Table 1-7: Cryo-Torr 250FH High Capacity Cryopump Specifications

Parameter	Specifications
Rough Pump Connection	NW 25 ISO KF
Integrated Hardware	Second Stage Diode
Pumping Speeds:	
Water	6500 liters/sec
Air	2200 liters/sec
Hydrogen	4500 liters/sec
Argon	1800 liters/sec
Argon Throughput	700 scc/min.
Capacity:	
Argon	1000 std.
Hydrogen	24 std. liters @ 5×10^{-6} Torr
Crossover	150 Torr-liters
Cooldown Time	
60 Hz	100 min.
50 Hz	120 min.
Dimensions	Refer to Installation/Interface drawing
Weight	48 lbs. (22 kg)

Table 1-8: Cryo-Torr 400 Standard Capacity Cryopump Specifications

Parameter	Specifications
Rough Pump Connection	NW 25 ISO KF
Integrated Hardware	Second Stage Diode
Pumping Speeds:	
Water	16,000 liters/sec
Air	6000 liters/sec
Hydrogen	5000 liters/sec
Argon	5000 liters/sec
Argon Throughput	500 scc/min. (6 Torr liters/second)
Capacity:	
Argon	2500 std.
Hydrogen	15 std. liters @ 5×10^{-6} Torr
Crossover	300 Torr-liters
Cooldown Time	
60 Hz	150 min.
50 Hz	180 min.
Dimensions	Refer to Installation/Interface drawing
Weight	160 lbs. (73 kg)

Table 1-9: Cryo-Torr 400 High Capacity Cryopump Specifications

Parameter	Specifications
Rough Pump Connection	NW 25 ISO KF
Integrated Hardware	Second Stage Diode
Pumping Speeds:	
Water	16,000 liters/sec
Air	6000 liters/sec
Hydrogen	12,000 liters/sec
Argon	5000 liters/sec
Argon Throughput	500 scc/min. (6 Torr liters/second)
Capacity:	
Argon	2500 std.
Hydrogen	42 std. liters @ 5×10^{-6} Torr
Crossover	300 Torr-liters
Cooldown Time	
60 Hz	150 min.
50 Hz	180 min.
Dimensions	Refer to Installation/Interface drawing
Weight	160 lbs. (73 kg)

Table 1-10: Cryo-Torr 500 Cryopump Specifications

Parameter	Specifications
Rough Pump Connection	NW 25 ISO KF
Integrated Hardware	Second Stage Diode
Pumping Speeds:	
Water	30,000 liters/sec
Air	10,000 liters/sec
Hydrogen	10,000 liters/sec
Argon	8400 liters/sec
Argon Throughput	500 scc/min. (6 Torr liters/second)
Capacity:	
Argon	3000 std. liters
Hydrogen	16 std. liters @ 5×10^{-6} Torr
Crossover	500 Torr-liters
Cooldown Time	
60 Hz	180 min.
50 Hz	220 min.
Dimensions	Refer to Installation/Interface drawing
Weight	205 lbs. (93 kg)

Table 1-11: Cryo-Torr 20HP Cryopump Specifications

Parameter	Specifications
Rough Pump Connection	NW 25 ISO KF
Integrated Hardware	Second Stage Diode
Pumping Speeds:	
Water	31,500 liters/sec
Air	10,000 liters/sec
Hydrogen	15,000 liters/sec
Argon	8,400 liters/sec
Argon Throughput	1500 scc/min. (19 Torr liters/second)
Capacity:	
Argon	5700 std. liters
Hydrogen	46 std. liters @ 5×10^{-6} Torr
Crossover	300 Torr-liters
Cooldown Time	150 min.
Dimensions	Refer to Installation/Interface drawing
Weight	152 lbs. (69 kg)

Theory of Operation

Your Cryo-Torr Cryopump consists of a cold head and a vacuum vessel. An 80K condensing array, a 15K array, cold head station heaters, and an 80K radiation shield are located in the vacuum vessel. The cold station heaters and 15K array are secured to the cold head, which is welded to the vacuum vessel. The cold head provides cooling to the three arrays. Gases are removed from your vacuum chamber, thereby creating a vacuum when they are condensed or adsorbed on the cryogenically-cooled arrays.

Cold Head

The cold head consists of a two-stage cold head cylinder (part of the vacuum vessel) and drive unit displacer assembly, that together produce closed-cycle refrigeration at temperatures that range from 60 to 120K for the first-stage cold station to 10 to 20K for the second-stage cold station, depending on operating conditions. Within the drive unit displacer assembly, the drive unit actuates the displacer-regenerator assembly located in the cold head cylinder and thereby controls the flow of helium into the cold head. Within the drive unit are located the crankcase and drive motor, which is a direct-drive constant-speed motor, operating at 72 rpm on 60Hz power and 60 rpm on 50 Hz power.

During operation, high pressure helium from the compressor enters the cold head at the helium supply connector, and flows through the displacer-regenerator assembly, crankcase, and motor housing before exiting through the helium gas return connector and returning to the compressor. Helium expansion in the displacer-regenerator assembly provides cooling at the first and second stage cold stations.

Vacuum Vessel and Arrays

The 80K condensing array, as shown in [Figure 1-3](#), condenses water and hydrocarbon vapors. The 15K array condenses nitrogen, oxygen, and argon while the specially processed charcoal of this array traps helium, hydrogen, and neon.

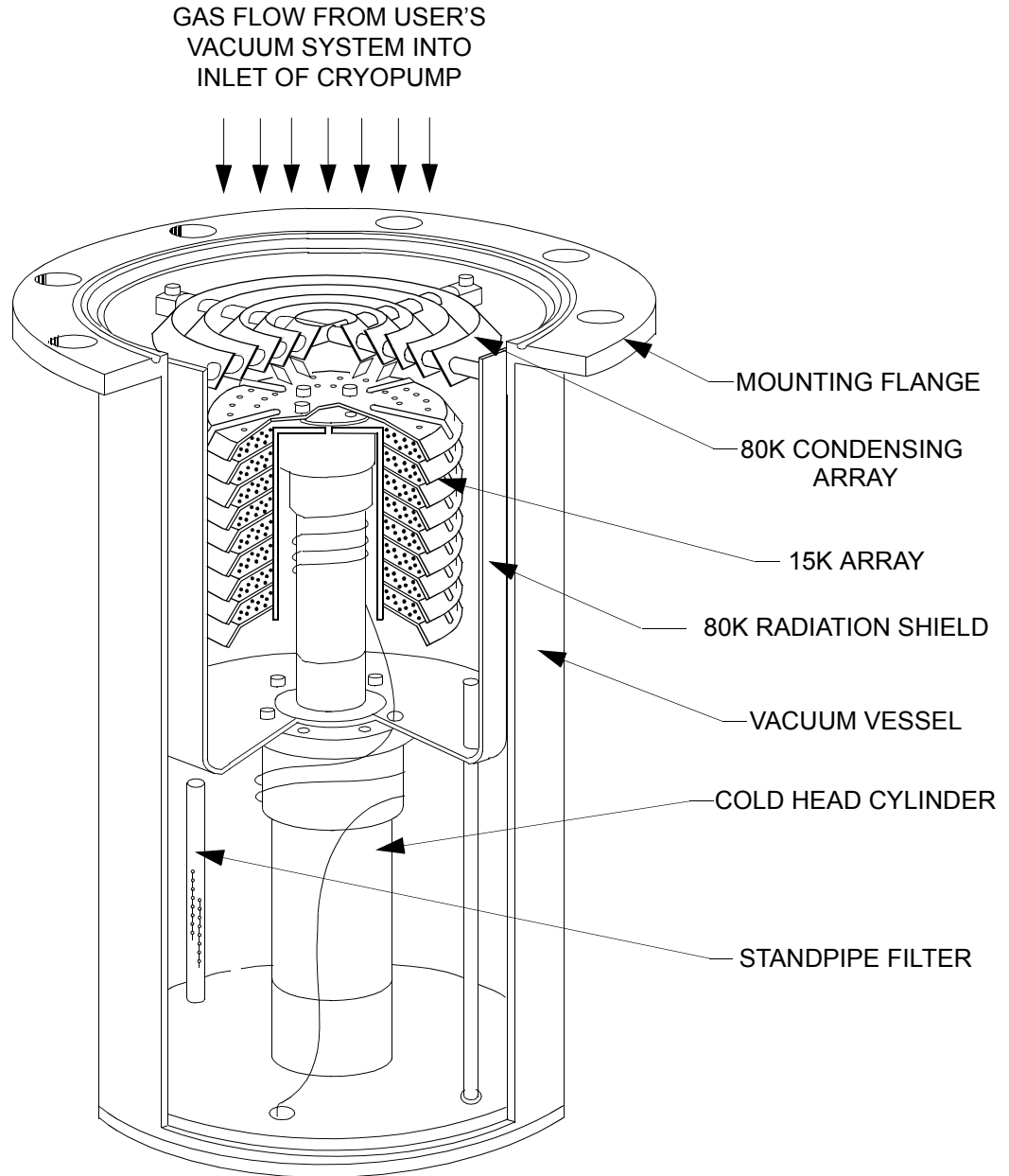

Figure 1-3: Cutaway View of a Typical Cryo-Torr Pump

Compressor Gas and Oil Flows

Helium returning from the cryopump cold head enters the compressor, and a small quantity of oil is injected into the gas stream, thereby overcoming helium's low specific heat and inability to carry heat produced during compression. Helium is then compressed and passed through a heat exchanger for removal of compression-caused heat.

The helium continues its flow through an oil-mist separator and a charcoal filter adsorber (cartridge), within the compressor, where oil and contaminants are removed. A differential pressure relief valve in the compressor limits the operating pressure differential between the helium supply and return lines, thereby allowing compressor operation without cold head operation. When cold head operation reaches a steady-stage condition, further pressure regulation is unnecessary.

Cryo-Torr Interface

The Cryo-Torr Interface, shown in [Figure 1-3](#), is required when; connecting more than one Cryo-Torr Cryopump to a variety of CTI-CRYOGENICS Compressors, or when connecting a single Cryo-Torr Cryopump to the 9000 AND 8510 Series of compressors.

The Cryo-Torr Interface accepts input cryopump power from the compressor and distributes it to a maximum of three Cryo-Torr Cryopumps. The Cryo-Torr Interface also supports a Compressor Remote feature which can be used to turn the Cryo-Torr Cryopumps off when the compressor is turned off.

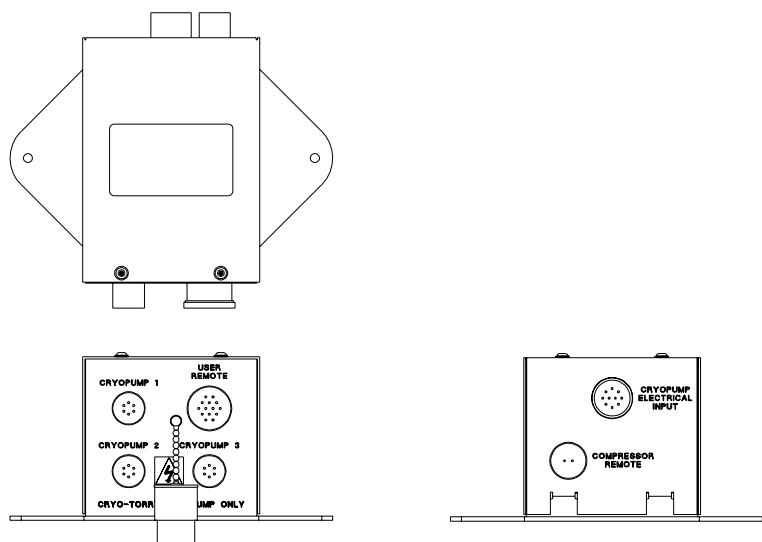

Figure 1-4: Cryo-Torr Interface

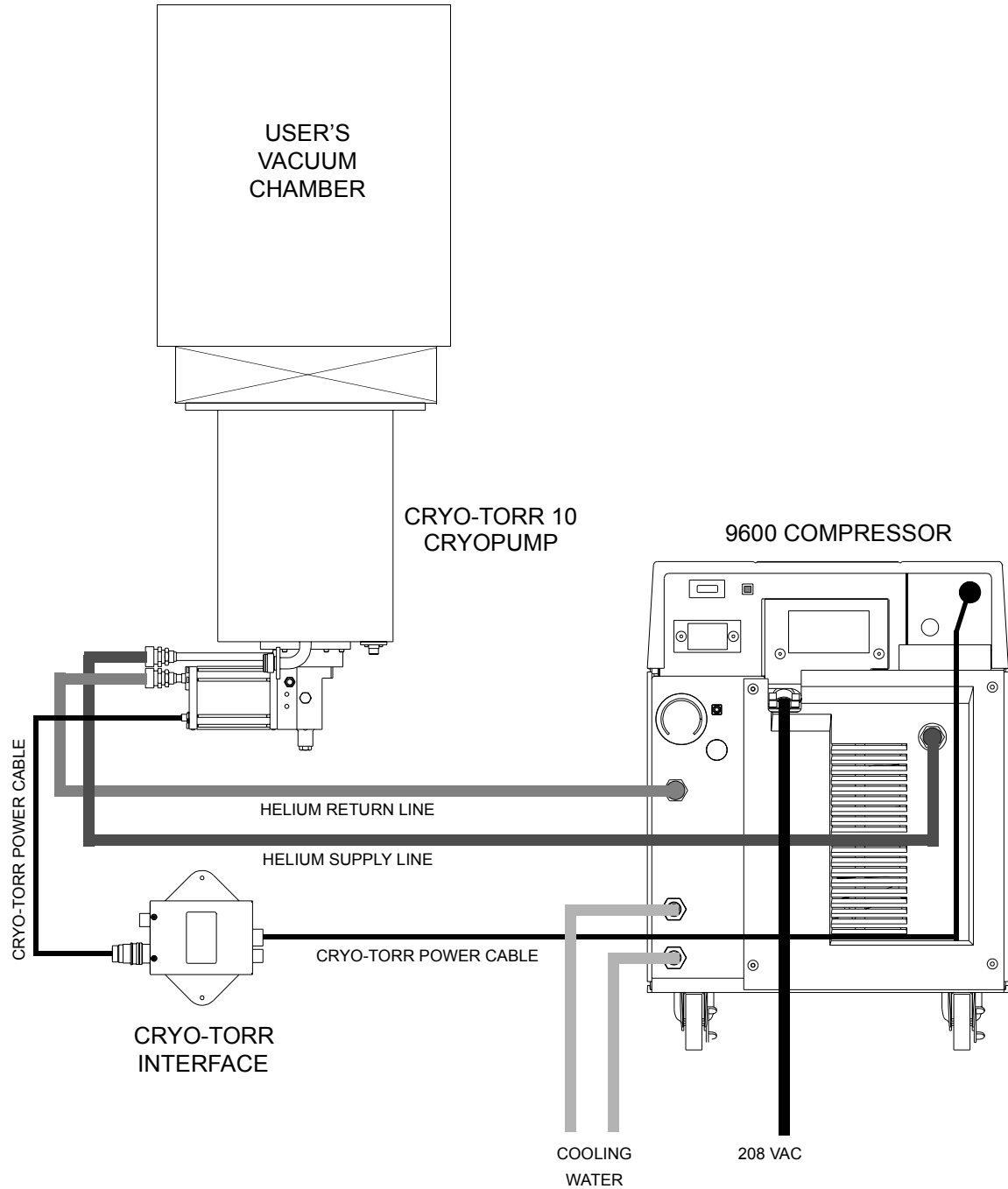

Figure 1-5: Typical Cryo-Torr System with 9000 Series Compressor

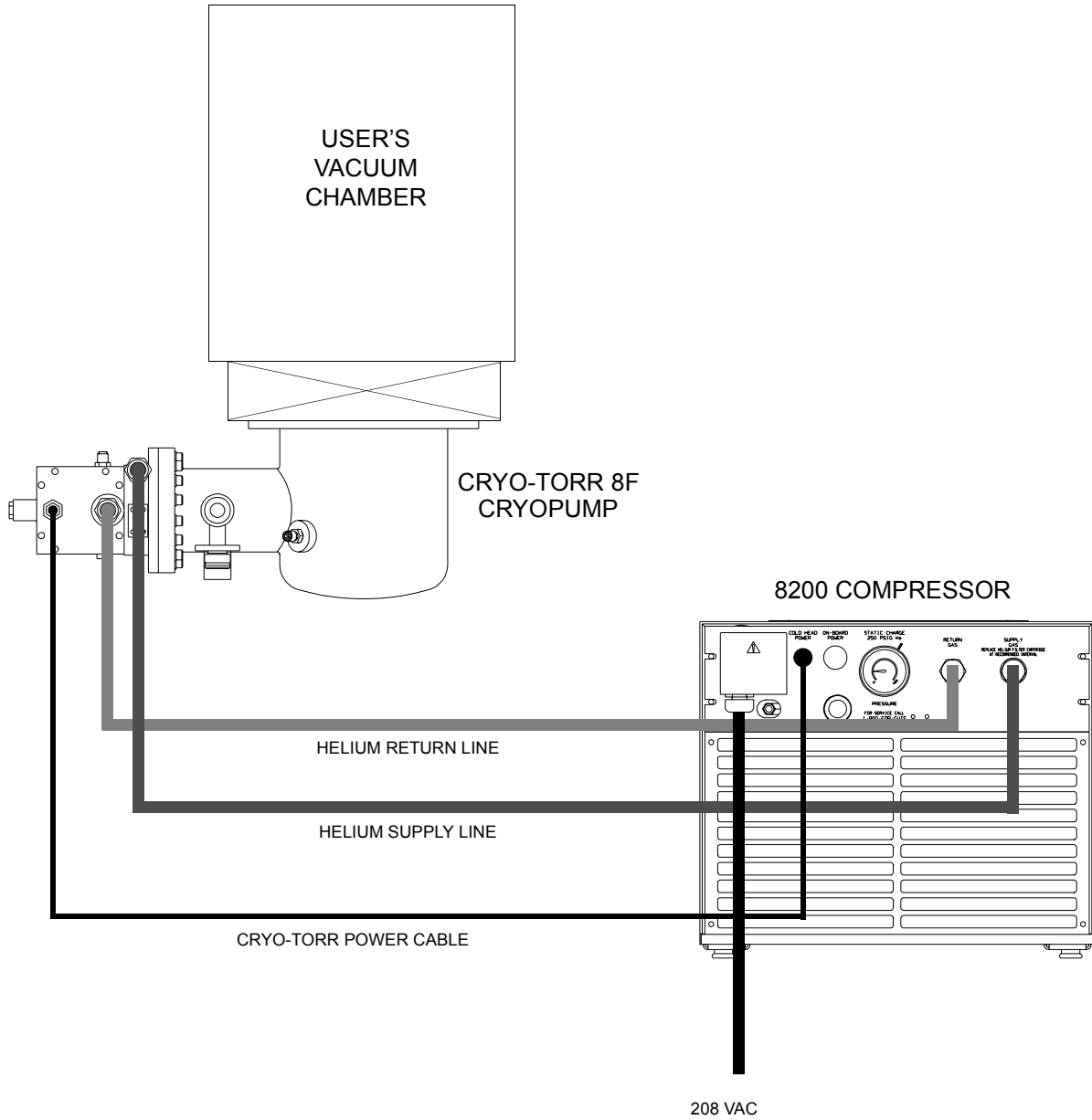

Figure 1-6: Typical Cryo-Torr System with 8200 Compressor

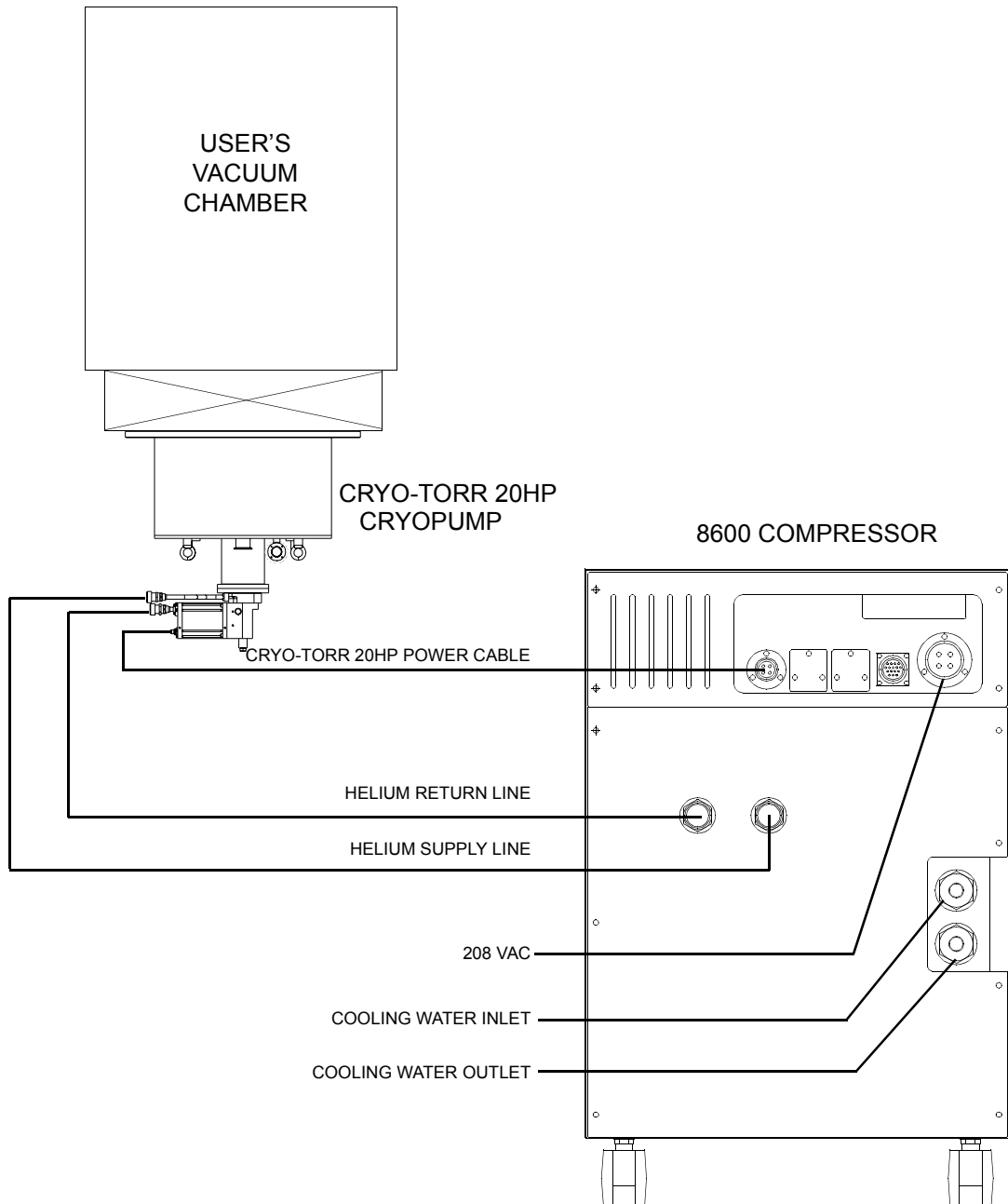

Figure 1-7: Typical Cryo-Torr System with 8600 Compressor

Section 2 - Installation

Introduction

Installation information is presented for experienced and non-experienced Cryo-Torr Cryopump system technicians. The flowchart in [Figure 2-1](#) highlights the major tasks for installation of Cryo-Torr Cryopumps. Refer to [Figure 2-1](#) and the appropriate installation procedure within this section for the type of cryopump being installed.

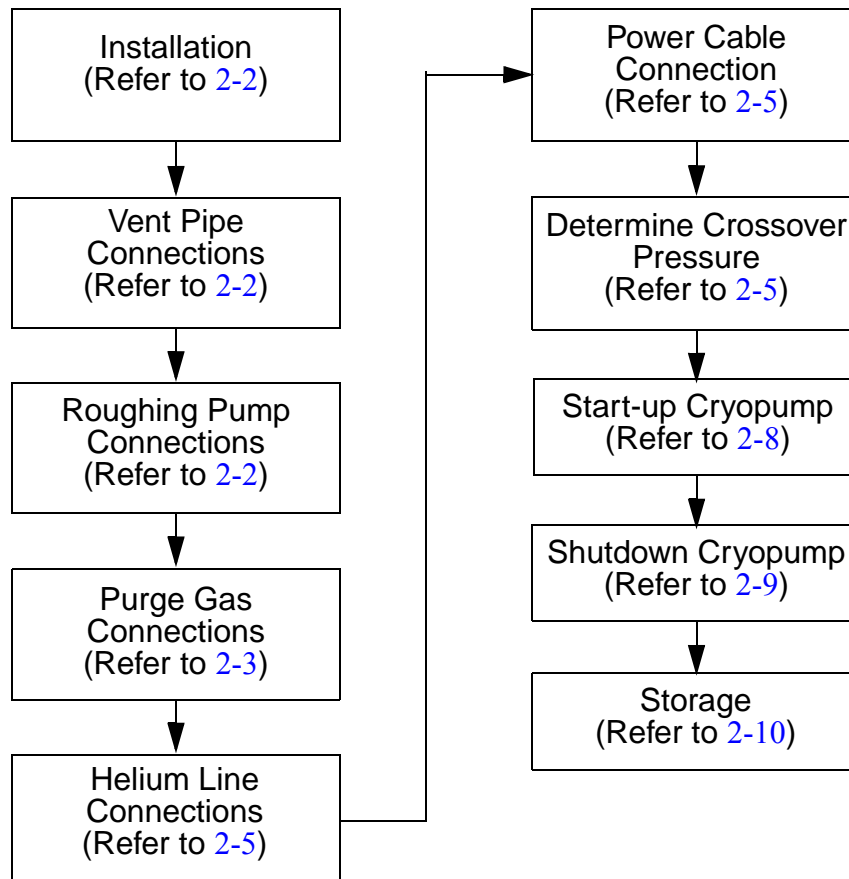

Figure 2-1: Block Diagram for Cryo-Torr System Installation

Installation

The cryopump may be installed in any orientation without affecting its performance.

Before mounting the cryopump to the vacuum system, a high-vacuum isolation valve (Hi-Vac valve) should be installed between the cryopump and vacuum chamber to isolate the cryopump from the chamber during rough pumping, cooldown, and regeneration.

Install the cryopump to the vacuum system as follows:

1. Remove the protective cover from the main flange of the cryopump.
2. Clean all sealing surfaces and install the O-ring or metal seal gasket as appropriate.
3. Mount the cryopump to the Hi-Vac valve or vacuum chamber mounting flange. Follow the mating flange manufacturer's recommendations for the required hardware and securing procedures. Use all of the required mounting hardware.

Vent Pipe Connection

The cryopump pressure relief valve can be vented directly into the room or can be connected to an exhaust system.



WARNING

If toxic, corrosive, or flammable gases are pumped, a vent pipe must be connected to the cryopump relief valve and directed to a safe location.

When connecting a vent pipe to your cryopump, the 1.30-inch diameter x 1.38-inch long volume around the relief valve must remain open for proper relief valve operation.

Vent pipe adapters are available from CTI-CRYOGENICS (P/N 8080250K008).

Roughing Pump Connection

Connect your Cryo-Torr Cryopump to a roughing pump system using a roughing line with the largest inside diameter possible to minimize the

roughing time required during start-up procedures prior to normal operation. The roughing pump should have a blank-off pressure of less than 20 microns. The roughing pump connects to the Cryo-Torr Cryopump roughing valve. The valve will accept an ISO NW-25 flange.

A molecular sieve roughing trap to minimize oil backstreaming from your roughing pump system is recommended and should be installed in the roughing pump line near the roughing pump. The trap must be properly maintained. Connect the roughing valve to the roughing pump as follows:

1. Install the roughing pump line to the cryopump roughing valve port using the clamp provided. Tighten the clamp securely.

Purge Gas Connection

Connect your purge gas supply line to the purge valve 1/8 NPTF fitting. Adjust the supply pressure to achieve 1-2 cfm.

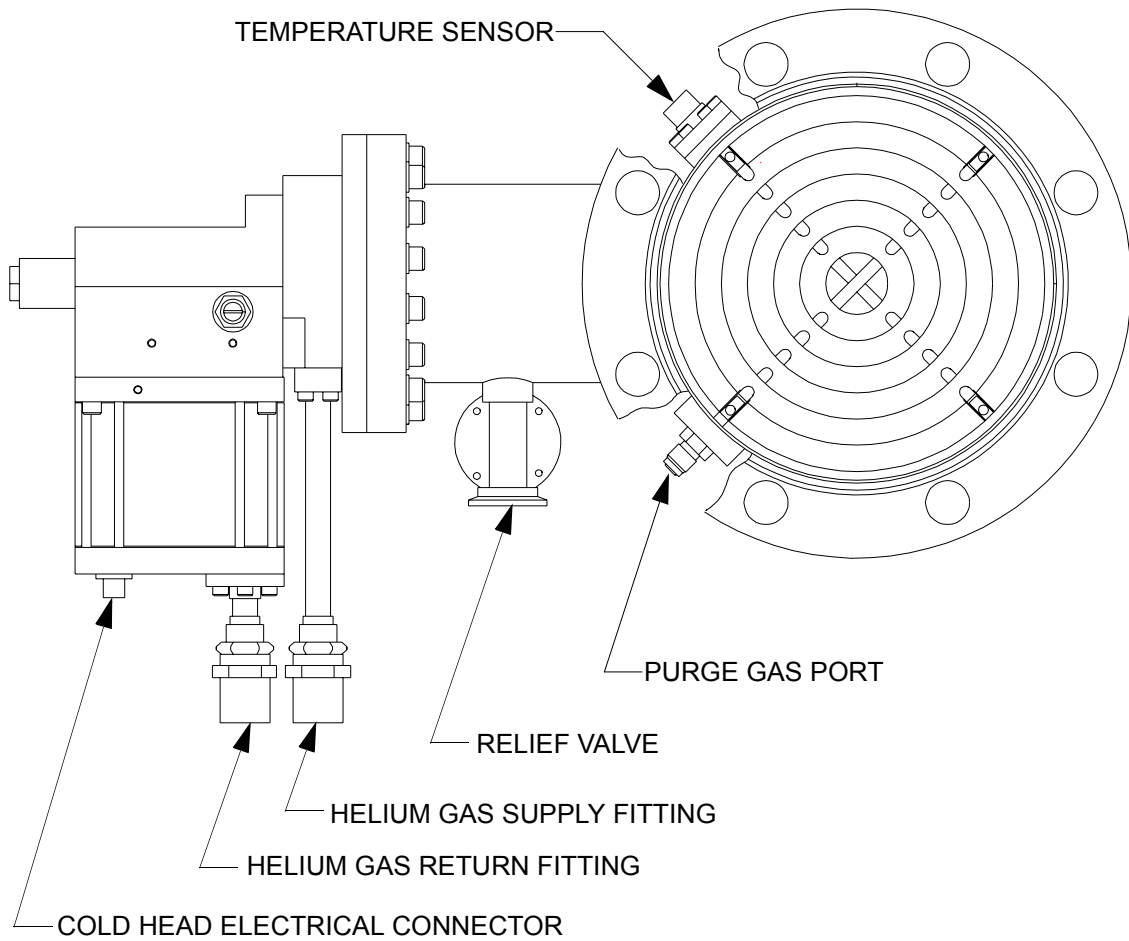

Figure 2-2: Gas/Electrical Components on a Typical Cryo-Torr Cryopump

Helium Return and Supply Line Connections

Make the connections between the cryopump and compressor. Refer to [Figure 2-2](#), while making the component interconnections.

1. Remove all dust plugs and caps from the supply and return lines, compressor, and cryopump. Check all fittings.
2. Connect the helium-return line from the gas-return connector on the rear of the compressor to the gas-return connector on the Cryo-Torr Cryopump.
3. Connect the helium supply line from the supply connector on the cartridge to the gas-supply connector on the Cryo-Torr Cryopump.
4. Attach the supply and return line identification decals (CTI-CRYOGENICS supplied) to their respective connecting piping ends.

NOTE: Verify proper helium supply static pressure as described in the Installation Section of the appropriate Compressor Manual.

Power Cable Connection

CAUTION

The system power circuit breaker switch at the back of the compressor must be in the OFF position before making any and all electrical connections.

Do not connect the compressor to its power source until all connections have been made between the components of the Cryo-Torr system.

1. Connect the Cryo-Torr power cable from the cold head connector on the compressor to the Cryo-Torr Cryopump power connector.

Crossover Pressure Calculations

Crossover is that point in time when the pumping of a vacuum chamber is switched from *rough* pumping to *high-vacuum* pumping. Rough pumping brings the vacuum chamber pressure from one atmosphere (760 Torr) down to a pressure of approximately 0.5 Torr. At crossover, the roughing valve is closed and the high vacuum valve is opened bringing the vacuum chamber

down to a pressure typically less than 10^{-6} Torr. This momentary pulse of gas and water molecules is cryo-condensed on the arrays of the Cryo-Torr Cryopump.

To determine the maximum permissible crossover pressure (CP), perform the following calculation using the crossover values (CV) for your model Cryo-Torr Cryopump shown in [Table 2-1](#) and the actual volume of your vacuum chamber (VC).

Table 2-1: Crossover Values

Cryo-Torr Pump	Torr-Liters
4	100
8	150
8F	150
10	300
100	40
250F	300
400	300
20HP	300
500	500

Where VC = 100 liters:

$$CP = \frac{\text{CROSSOVER VALUE}}{\text{VACUUM CHAMBER VOLUME}} = \frac{CV}{VC}$$

$$CP = \frac{300 \text{ TORR-LITERS}}{100 \text{ LITERS}} = 3 \text{ TORR}$$

Optimizing Crossover Pressure

The calculated crossover pressure may not be optimized for your system. To help prevent any backstreaming during the roughing of the vacuum chamber, you should stop roughing at as high a pressure as possible. The optimum crossover pressure for a vacuum chamber should cause a very

slight rise in temperature with a rapid recovery. Increase the roughing pressure in small increments (15-20%) until the rise in temperature is noted; then drop the value by a small amount (10%). This will be the optimum pressure for that vacuum chamber.

Cryo-Torr Cryopump Capacity Calculations

Cryopump capacity is defined as the total standard liters of gas that can be accommodated within a cryopump prior to regeneration. The number of hours between regeneration cycles can be easily calculated in the case of a continuous gas flow of a known gas species:

$$A = \frac{16.6 \times C}{B}$$

Where:

A = Duration of operation with a continuous gas flow (hours)

B = Gas flow (scc/min.)

C = Cryo-Torr capacity for the particular gas species being flowed (std. liters) as shown in [Table 2-2](#).

Table 2-2: Condensable Gases Capacity (Argon, Nitrogen, Oxygen, etc.)

Parameter	Value
Cryopump	Cryo-Torr 10F
Standard Liters	2000
Torr-Liters	1,500,000

Example:

For a sputtering application of continuously flowing argon gas at 70 scc/min, the duration of continuous operation with this gas flow (between regeneration) would be:

$$A = \frac{16.6 \times 2000 \text{ (std liters)}}{70 \text{ (scc/min)}} = 474 \text{ hours}$$

Crossover Cycle Calculations

The number of crossover cycles between regeneration cycles can also be easily calculated when the crossover pressure and vacuum chamber volume are known:

$$N = \frac{760,000 \text{ Torr-liters}}{P \times V}$$

Where:

N = Number of crossover cycles

V = Volume of vacuum chamber (liters)

P = Pressure of vacuum chamber prior to crossover (Torr)
(roughing pressure)

Example:

For a vacuum chamber of 100 liters and a roughing pressure of 1.5 Torr, the number of crossover cycles between regeneration cycles would be:

$$N = \frac{760,000 \text{ Torr-liters}}{1.5 \text{ (Torr)} \times 100 \text{ (liters)}} = 5,060 \text{ cycles}$$

Cryopump Start-up Procedure

1. Close the Hi-Vac valve to isolate the Cryo-Torr Cryopump.
2. Initiate a Nitrogen purge of the Cryo-Torr Cryopump for one hour.

3. Open the roughing valve and rough the Cryo-Torr Cryopump to 50 microns. Close the roughing valve.

NOTE: If step 4 cannot be achieved, repeat step 3.

4. Check the rate-of-rise. The rate-of-rise should be 10 microns/minute.

NOTE: Cryo-Torr Cryopump power is turned ON/OFF when compressor power is turned ON/OFF.

5. Turn compressor power ON.
6. Wait for the second stage temperature (T2) to be less than 17 K.
7. Open the Hi-Vac valve.

Cryopump Shutdown Procedure

Typically, a cryopump can be left in operation continuously if you are not processing or not using the vacuum chamber, by simply closing the Hi-Vac valve to isolate the cryopump from your vacuum chamber. You are now able to load, unload, repair or replace components in the chamber and the cryopump will be available for restarting the process as necessary.

1. Close the Hi-Vac valve to isolate the cryopump.
2. Shut off the cryopump by removing the input power cable to the cryopump motor.
3. Initiate Nitrogen gas purge.
4. Continue Nitrogen gas purge until ambient temperature is reached.
5. Shut off the Nitrogen gas purge.

Cryopump Storage

WARNING



If the cryopump has been used to pump toxic or dangerous materials, you must take adequate precautions to safeguard personnel. If such a cryopump is shipped to a Product Service Department, clearly mark on all storage cartons the identity of the toxic or dangerous materials to which the cryopump has been subjected. All shipped equipment that contains hazardous/toxic materials must conform to DOT regulations.

If the cryopump is stored while attached to your vacuum system, the cryopump vacuum vessel should be kept at a slight positive atmospheric pressure with dry nitrogen or argon.

If the cryopump is removed from your vacuum system, install the protective cover on the mounting flange of the cryopump vacuum vessel inlet before storage.

The remaining components of your Cyro-Torr high vacuum pump system are fully protected during storage if kept under positive helium pressure and all component connections left connected. Periodically, check the helium supply pressure gauge on the compressor and refer to the compressor manual for the proper static charge pressure.

Section 3 - Regeneration

Introduction

A Cryo-Torr cryopump periodically requires a regeneration cycle to return it to its original operating capabilities.

Gases captured from a vacuum chamber and trapped in the cryopump through condensation and cryo-adsorption are held primarily in an ice-like form. A regeneration cycle removes trapped gases through a process similar to defrosting a refrigerator freezer compartment.

During a regeneration cycle, the cryopump is warmed to room temperature or higher, allowing trapped gases to change from a solid state to a gaseous state and thereby released from the cryopump through the pressure relief valve to the atmosphere.

	<p style="text-align: center;">WARNING</p> <p>If toxic, corrosive, or flammable gases are pumped, a vent pipe must be connected to the cryopump relief valve and directed to a safe location.</p>
--	--

When to Regenerate

The need to regenerate the Cryo-Torr pump as a result of saturation is a function of the cryopump capacity and the process gas throughput.

If the cryopump becomes incapable of maintaining a high-vacuum (typically an increase in your vacuum chamber base pressure by a factor of 10, even though the cold head and compressor unit are operating satisfactorily), the cryopump requires regeneration.

It is recommended that your cryopump be regenerated on a regular schedule coinciding with system maintenance, weekend system shutdown, etc. A suitable time interval between regeneration cycles can be determined from experience.

Extended loss of electrical power (10 minutes or longer), system vacuum failure, such as venting with a partially open vacuum isolation valve, and operator error may necessitate cryopump regeneration.

NOTE: Short term electrical outages of up to 10 minutes should not result in the need to regenerate your cryopump.

Assisted Regeneration

A regeneration cycle incorporating the use of a heated dry inert purge gas (nitrogen/argon) is the preferred method of regeneration and will overcome unassisted regeneration technical difficulties by:

- Minimizing the required time to bring the condensing and cryo-adsorbing arrays to room temperature
- Reducing the time required to rough the cryopump because the dry inert purge gas will minimize the amount of residual water vapor in the 15K array
- Diluting hazardous gases and ensuring their removal from the cryopump housing

Table 3-1: Required Accessories for Assisted Regeneration

Part Number	Description
8080250K020	Purge Gas Heater, 110 V
8080250K023	Purge Gas Solenoid Valve, 110V

NOTE: Call 1-800-FOR GUTS to obtain the accessories listed in Table 3-1:

1. Close the Hi-Vac isolation valve.
2. Shut off the cryopump by setting the System Power switch on the compressor to the OFF position.
3. Immediately introduce heated dry purge gas through the vacuum vessel purge fitting at approximately 150° F (66° C) and at a flow rate of 1 -2 cfm. Allow the purge gas to vent through the relief valve.
4. Halt the gas purge when the condensing arrays reach 80° F (26° C) (300K).

5. When the condensing arrays reach ambient temperature, rough the cryopump to an initial starting pressure, usually between 50 and 100 microns.

NOTE: *After roughing, perform a rate-of-rise (ROR) test to ensure that your cryopump regeneration has been thorough and that no air-to-vacuum leaks are present.*

6. Perform the rate-of-rise test as follows:
 - a. Once the roughing cycle has roughed the cryopump starting pressure to between 50 - 100 microns, close the roughing valve.
 - b. Observe the rate of pressure rise (ROR) over a five minute period.

NOTE: *The ROR should be less than 10 microns/minute over a five minute period (50 microns total).*

- c. If the ROR is greater than 50 microns, repurge the cryopump, check for leaks, and repeat steps 5 and 6.
7. Close the cryopump roughing valve and start the cryopump.
8. The cryopump is ready for use when the second stage array reaches a temperature of 20K or lower.

Section 4 - Troubleshooting

Troubleshooting the Cryopump

The primary indication of trouble in a vacuum pumping system is a rise in base pressure in your vacuum chamber. A rise in the base pressure may be caused by a leak in the vacuum system or by a fault in the cryopump or saturation of the 15K cryo-adsorbing charcoal array (regeneration may be necessary). If the cryopump temperature is below 20K it must pump at rated capacity; a high base pressure is usually caused by an air-to-vacuum leak in the system.

If you suspect a leak in your vacuum system, isolate the cryopump by closing the Hi-Vac valve and leak check your vacuum chamber. If no leaks are found, a leak may be present below the Hi-Vac valve (cryopump). Leak checking below the Hi-Vac valve should be performed with the cryopump shut OFF and at room temperature. Leak checking while the cryopump is operating may mask leaks that are present (due to the ability of the cryopump to pump helium). If no leak is found, refer to the cryopump troubleshooting procedures summarized in [Table 4-1](#).

The problems presented in [Table 4-1](#) are followed by possible causes and corrective actions. The causes and corresponding actions are listed in their order of probability of occurrence.

Maintaining a log of certain parameters during normal operation can be a valuable tool in troubleshooting the cryopump. The log may contain many parameters, however, the following minimum parameters should be included: the cooldown time to 20K, the roughing time to 50 μ , the time to base pressure at crossover, the time between regeneration cycles, and the compressor pressure reading.

Technical Inquiries

Please refer to **Appendix A** of this manual for a complete list of the CTI-CRYOGENICS' world wide customer support centers.

Table 4-1: Troubleshooting Procedures

Problem	Possible Cause	Corrective Action
High base pressure of vacuum system, and a cryopump temperature <i>below</i> 20K.	Air-to-vacuum leak in vacuum system or in cryopump.	Check cryopump relief valve for proper seating. Check cryopump for leaks. Check vacuum chamber and Hi-Vac valve for leaks.
	High partial pressure of non-condensables (helium, hydrogen, or neon) within the cryopump because the 15K array has reached full capacity.	Regenerate the cryopump as described in Section 3 - Regeneration .
	One of the arrays is loose, which is preventing good thermal contact with the cold station.	Warm the cryopump to ambient temperature and retighten the array mounting screws to 15 - 20 in. lbs.
High base pressure of vacuum system, and a cryopump temperature <i>above</i> 20K.	Decrease in cryopump cold head performance.	If the helium return pressure gauge reads below the normal-operating return pressure 60-85 psig (415-590 kPa), add gas as described in the appropriate Compressor manual.
	High partial pressure of non-condensables (helium, hydrogen, or neon) within the cryopump because the 15K array has reached full capacity.	Regenerate the cryopump as described in Section 3 - Regeneration .
	Excessive thermal load on frontal array.	Reduce the thermal radiation load by 1) shielding the cryopump or 2) lowering the temperature of the radiating surface.

Table 4-1: Troubleshooting Procedures (Continued)

Problem	Possible Cause	Corrective Action
Cryopump fails to cool down to the required operating temperature or takes too long to reach that temperature (20K).	Low helium supply pressure.	Add gas as described in the appropriate Compressor manual.
	Compressor problems.	Refer to Troubleshooting section of the appropriate Compressor manual.
	Vacuum leak in vacuum system or cryopump.	Check the cryopump relief valve for proper seating. Check cryopump for leaks. Check vacuum system for leaks.
	Incomplete regeneration may not have fully cleaned the adsorbing array. Partial pressures of non-condensables (hydrogen, neon or helium) may remain.	Regenerate the cryopump as described in Section 3 - Regeneration .

Section 5 - Maintenance Procedures

Helium Circuit Decontamination

Contamination of the helium-gas circuit is indicated by sluggish or intermittent operation (ratchetting) of the cold head drive mechanism. With severe contamination the cold head drive may seize and fail to operate. One of the major sources of contamination is using helium gas of less than the required purity. When performing the decontamination process, use only 99.999% pure-helium gas, and the regulator and charging line must be properly connected and purged.

This decontamination procedure will remove contaminants from the cold head and/or compressor, thereby restoring system performance. The cold-trapping of contaminants inside the cold head during this procedure will also decontaminate the compressor if the contamination of the system is not severe. Separate decontamination of the compressor is required whenever the compressor has been opened to atmosphere, or the pressure dropped to zero.

Cryo-Torr Cryopump Decontamination Procedures

NOTE: Refer also to the appropriate Compressor Manual.

1. Cool down the cryopump and operate it for one to three hours. If the system will not cool down, proceed to step 2. Operating the cryopump will isolate the contaminants by "freezing" them in the cold head. The contaminants in the helium-gas circuit of the cryopump tend to become frozen inside the cold head. The longer the cryopump is operated beyond the one-hour period, the greater is the amount of contamination that becomes isolated inside the cold head.
2. Shut down the cryopump as described in [Section 2 - Installation](#).
3. *Immediately* disconnect the helium supply and return lines from the gas-supply and gas-return connectors at the rear of the compressor. Leave them attached to the cold head.
4. Attach the maintenance manifold to the disconnected ends of the return and supply lines.

5. Reduce the pressure in the cold head to a level of 30 psig by using the maintenance manifold. Reducing the pressure in the cold head to below 30 psig (200 kPa) may introduce more contaminants into the helium circuit.

If you only have the manual regeneration option, turn the cryopump OFF and open the purge valve until the second stage temperature reaches 290K.



6. Attach a two-stage regulator (0-3000/0-400 psig) and charging line to a helium bottle (99.999% pure). **DO NOT OPEN THE BOTTLE VALVE AT THIS TIME.** Purge the regulator and charging line as introduced in steps a through d below. Do *not* use helium gas that is *less than 99.999% pure*.
 - a. Open the regulator a small amount by turning the adjusting knob clockwise until it contacts the diaphragm; then, turn approximately 1/8 to 1/4 turn more, so that the regulator is barely open.
 - b. Slowly open the bottle valve, and purge the regulator and line for 10 to 15 seconds. Turn the regulator knob counter-clockwise until the helium stops flowing.
 - c. Loosely connect the charge line to the 1/8-inch Hoke valve on the maintenance manifold.
 - d. Purge the charge line again, as in step a, for 30 seconds, and tighten the charge line flare fitting onto the Hoke valve while the helium is flowing.

This procedure is required to ensure that both the regulator and the charging line will be purged of air and that the air trapped in the regulator will not diffuse back into the helium bottle. For best results, CTI-CRYOGENICS suggests a dedicated helium bottle, regulator, and line, which are never separated, for adding helium.

7. Perform in sequence:
 - a. Backfill the cold head with helium to a static charge pressure of 195-205 psig (1345-1415 kPa) by adjusting the regulator to the required pressure, and opening the Hoke valve on the manifold. Close the Hoke valve when the pressure is correct.
 - b. Depressurize the cold head to 30 and 50 psig 200 and 330 kPa) by slowly opening the ball valve and allowing the helium to bleed out slowly. Do *not* reduce the pressure to *less than 30 psig* or the cold head may be further contaminated.

- c. Perform the flushing steps a and b four more times.
 - d. Pressurize the cold head to a static charge pressure of 195-205 psig (1345-1415 kPa) and run the cold head drive motor for 10 to 30 seconds.
 - e. Perform steps b through d four more times for a total of 25 flushes and 5 drive-motor runs.
8. Verify that the cold head is pressurized to the static charge pressure of 195-205 psig (1345-1415 kPa).
 9. Disconnect the maintenance manifold from the helium return and supply lines.
 10. Reconnect the helium return and supply lines to the return and supply connectors at the rear of the compressor. The cryopump is now ready for operation.

Cleaning the Cryo-Torr Cryopump

	WARNING
	If the cryopump has been used to pump toxic or dangerous materials, you must take adequate precautions to safeguard personnel.

Cleaning the arrays or other interior surfaces of the cryopump vacuum vessel is seldom required because dust build-up does not affect performance, and the special alloy copper cryo-condensing arrays are nickel plated for corrosion resistance.

If you wish to clean the arrays and other interior surfaces, follow the procedures below.

1. Confirm that an adequate supply of indium gasket material, P/N 3543738P001, is available to replace gaskets inadvertently damaged during disassembly.
2. Carefully disassemble the components in the vacuum vessel, including the arrays and radiation shield, to avoid damage to the indium gaskets.
3. Clean the interior surface of the vacuum vessel, the 80K condensing array, and the 80K radiation shield as follows:

- a. Wash each item in strong soap or detergent solution and hot water.
- b. Rinse the item in *clean hot water*.
- c. Air or oven dry all items at 150°F (66°C) maximum before reinstalling into the cryopump.

CAUTION

Do not clean the 15K cryo-adsorbing array, because you may severely contaminate the adsorbent in the cleaning process.

4. Wearing lint-free gloves, reassemble the cryopump. Replace any indium gasket damaged during disassembly with a gasket cut from indium gasket material.
5. Torque all screws that compress indium gaskets for a minimum of 5 seconds to allow proper gasket seating:

Table 5-1: Indium Gasket Screw Torque Specifications

Screw Thread	Torque (Inch-Pounds)
No. 4-40	11
No. 6-32	20

Appendix A - Customer Support Information

Customer Support Center Locations

To locate a Customer Support Center near you, please visit our website www.helixtechnology.com on the world wide web and select *CONTACT* on the home page.

Guaranteed Up-Time Support (GUTS)

For 24 hour, 7 day per week Guaranteed Up-Time Support (GUTS) dial:

800-367-4887 - Inside the United States of America

508-337-5599 - Outside the United States of America

Product Information

Please have the following information available when calling so that we may assist you:

- Product Part Number
- Product Serial Number
- Product Application
- Specific Problem Area
- Hours of Operation
- Equipment Type
- Vacuum System Brand/Model/Date of Manufacture

E-mail

For your convenience, you may also e-mail us at:

techsupport@helixtechnology.com

Index

A

Arrays and vacuum vessel
operation, 1-15

C

Calculations
capacity, 2-7
Capacity calculations, 2-7
Cleaning Cryo-Torr pump, 5-3
Cold head
operation, 1-15
Compressor gas and oil flows
operation, 1-17
Crossover cycle
calculations, 2-8
Crossover pressure
optimizing, 2-6
Crossover pressure calculations, 2-5
Cryo-Torr 10
specifications, 1-7
Cryo-Torr 10F
specifications, 1-8
Cryo-Torr 20HP
specifications, 1-14
Cryo-Torr 250F
specifications, 1-9
Cryo-Torr 250FH
specifications, 1-10
Cryo-Torr 400 High Capacity
specifications, 1-12
Cryo-Torr 400 Standard Capacity
specifications, 1-11
Cryo-Torr 4F
specifications, 1-4
Cryo-Torr 500
specifications, 1-13
Cryo-Torr 8
specifications, 1-5
Cryo-Torr 8F

specifications, 1-6
Cryo-Torr interface, 1-17
Cryo-Torr pumps
installation, 2-1
introduction, 1-1
theory of operation, 1-15

D

Decontamination
procedures, 5-1

H

Helium return and supply line
connections, 2-5

I

Installation
crossover pressure calculations, 2-5
helium return and supply line connections, 2-5
power cable connection, 2-5
pumps, 2-1
purge gas connection, 2-3
roughing pump connection, 2-2
vent pipe connection, 2-2
Installation, operation, and service
instructions, 1-1
Interface
Cryo-Torr, 1-17

M

Maintenance, 5-1
cleaning, 5-3
decontamination procedures, 5-1
helium circuit decontamination, 5-1

O

Oil flows and compressor gas
operation, 1-17

P

- Power cable connection
 - installation, 2-5
- Purge gas connection
 - installation, 2-3

R

- Regeneration
 - assisted, 3-2
 - introduction, 3-1
 - when to, 3-1
- Roughing pump connection
 - installation, 2-2

S

- Safety precautions, S-1
- Shutdown procedure, 2-9
- Start-up procedure, 2-8
- Storage, Cryopump, 2-10

T

- Theory of operation
 - pumps, 1-15
- Troubleshooting, 4-1

V

- Vacuum vessel and arrays
 - operation, 1-15
- Vent pipe connection
 - installation, 2-2