



Trillium US Inc.
Model 250 / Model 350 Cryogenic Helium Compressor
User's Manual
Rev G / June 2020



For information about Trillium US Inc., visit the Trillium US Inc. Web site at:

<http://www.trilliumus.com>

How to Contact Trillium US Inc. Support:

support@trilliumus.com

For contact information and a complete listing of Direct Sales, Distributor, and Sales Representative contacts, visit the Trillium US Inc. Web site at:

<http://www.trilliumus.com>

Trillium US Inc. has made its best effort to ensure that the information contained in this document is accurate and reliable. However, the information is subject to change without notice and is provided "AS IS" without warranty of any kind (express or implied). Before placing orders, customers are advised to obtain the latest version of relevant information to verify that information being relied upon is current and complete. All products are sold subject to the terms and conditions of sale supplied at the time of order acknowledgment, including those pertaining to warranty, patent infringement, and limitation of liability. No responsibility is assumed by Trillium US Inc. for the use of this information, including use of this information as the basis for manufacture or sale of any items, nor for infringements of patents or other rights of third parties. This document is the property of Trillium US Inc. and by furnishing this information, Trillium US Inc. grants no license, expressed or implied, under any patents, copyrights, trademarks, trade secrets, or other intellectual property rights of Trillium US Inc. Trillium US Inc., copyright owner of the information contained herein, gives consent for copies to be made of the information only for use within the customer's organization as related to the use of Trillium US Inc. products. The same consent is given for similar information contained on any Trillium US Inc. Web site or disk used to distribute information to a customer. Trillium US Inc. does give consent to the copying or reproduction by any means of the information contained herein for general distribution, advertising or promotional purposes, or for creating any work for resale. The names of products of Trillium US Inc. or other vendors and suppliers appearing in this document may be trademarks or service marks of their respective owners that may be registered in some jurisdictions. A list of Trillium US Inc. trademarks and service marks can be found at:

<http://www.trilliumus.com/>

Trillium US Inc.
1340 Airport Commerce Dr.
Bldg. 1 Suite 175
Austin, Texas 78741 USA
TEL. +1 512 441 6893
FAX +1 512 443 6665
Email: insidesales@trilliumus.com

Copyright (©) 2015 by Trillium US Inc., All rights reserved.



Table of Contents

- 1 Revision History vi
- 2 Preface 1
 - 2.1 About Trillium US Inc..... 1
 - 2.2 Other Services from Trillium US Inc. 1
 - 2.3 About this Manual..... 1
 - 2.4 Compatibility 1
- 3 Safety Warnings 2
 - 3.1 Standards for the Use of Warnings and Cautions 2
 - 3.2 Warnings Applicable to All Aspects of M250/M350 Operation 2
 - 3.2.1 High Voltage and Electrical Shock Warnings 2
 - 3.2.2 High Pressure Related Warnings 3
 - 3.2.3 Helium Gas-Related Warnings..... 3
 - 3.2.4 Heat-Related Warnings 3
 - 3.3 Operator Instructions..... 4
- 4 Introduction 4
 - 4.1 General Information about the Model 250 / Model 350 Compressor..... 4
 - 4.1.1 Model 250 / Model 350 Features 4
 - 4.1.2 Overview of Model 250 / Model 350 Compressor Design & Operation..... 4
 - 4.1.3 Description of Subsystems 5
 - 4.1.4 Operational Flow 6
 - 4.2 Specifications 6
 - 4.3 Ordering Information 7
- 5 Installation..... 8
 - 5.1 Safety Warnings 8
 - 5.2 Installation Steps 8
 - 5.2.1 Unpacking and Inspection 8
 - 5.2.2 Mounting the Compressor 9
 - 5.2.3 Preparing the Compressor for Operation 9
 - 5.2.4 Installation..... 10
 - 5.2.5 Electrical Connection 12
- 6 Operation 12
 - 6.1 Before Switching ON the System 12
 - 6.2 Normal Operation 13
 - 6.2.1 Cycle Times..... 13
 - 6.3 Electronics Interface Connections..... 13
 - 6.3.1 Remote Interface..... 13



6.3.2	D-Sub User Controls	14
6.3.3	D-Sub User Status	15
6.3.4	Compressor Front Panel User Interface	16
6.3.5	Compressor Operational Checks	17
6.3.6	Compressor Maintenance Warning.....	17
6.3.7	Compressor System Shut Down	17
6.3.8	USB Interface (J1-Maintenance).....	18
6.3.9	Communications via USB.....	18
7	Troubleshooting	23
7.1	Troubleshooting Activities.....	23
8	Maintenance	24
8.1	Maintenance Personnel Requirements.....	24
8.2	Removing the Compressor from Service: Removal, Transport and Storage	24
8.3	Scheduled Preventative Maintenance Activity	25
8.3.1	Remove the Compressor Adsorber	25
8.3.2	Install Replacement Adsorber	29
8.4	Unscheduled Corrective Maintenance.....	30
8.4.1	Removing Helium Contamination.....	30
8.5	Returning Equipment	31

List of Figures

Figure 1	– Model 250 / Model 350 Compressor Internal Tip &Tells.....	9
Figure 2	– Model 250 / Model 350 Packaging Tip &Tells.....	9
Figure 3	– M250/M350 Recommended Minimum Water Flow Rate vs. Water Inlet Temperature.....	10
Figure 4	– User Control Signal Interface	15
Figure 5	– User Status Signal Interface	16
Figure 6	– Removal of Cover Panels.....	26
Figure 7	– Adsorber Aeroquip OMS Supply Line Removal	27
Figure 8	– Adsorber Aeroquip Nut Removal	28
Figure 9	– Adsorber Chassis Screw Removal	28
Figure 10	– Adsorber Removal.....	29
Figure 11	– Self Sealing Connector	29
Figure 12	– M250 / M350 Water Piping and Instrumentation Diagram.....	32
Figure 13	– M250 / M350 Water Cooled General Dimensions.....	33
Figure 14	– M250 Low Volt Single Phase Multi-Drive Schematic, 93-00300-001	34
Figure 15	– M350 Low Volt Three Phase Multi-Drive Schematic, 93-00300-000	35
Figure 16	– M250/M350 Fault Tree: Compressor will Not Start / Adsorber Replacement	36
Figure 17	– M250/M350 Fault Tree: Compressor Starts but Shuts Off	37
Figure 18	– M250/M350 Fuse Locations Multi-Drive	38
Figure 19	– 99-00074-000 Tool Kit Contents	39
Figure 20	– 99-00074-001 Tool Kit Contents	40
Figure 21	– 99-00250-000 Kit Contents	41



List of Tables

Table 2-1: Model 250 / Model 350 Helium Compressor Coldhead Compatibility	2
Table 2-2: Model 250 / Model 350 Helium Compressor Cryopump Compatibility	2
Table 4-1: Description of Model 250 / Model 350 Helium Compressor Subsystems	5
Table 4-2: Power Requirements for Model 250 / Model 350 Compressor	6
Table 4-3: Model 250 / Model 350 Helium Compressor Specifications	6
Table 4-4: Model 250 / Model 350 Helium Pressure Requirements	7
Table 4-5: Model 250 / Model 350 Helium Compressor Ordering Information	7
Table 4-6: Model 250 / Model 350 Optional Accessories and Replacement Parts.....	7
Table 6-1: J3 Remote Connector (25 Pin D-Sub).....	14
Table 6-2: Remote Interface Inputs	15
Table 6-3: Remote Interface Outputs	16
Table 6-4: Operational Checks	17
Table 6-5: USB Packet Format	18
Table 6-6: USB Maintenance Interface Command ID's.....	18
Table 6-7: ACK Payload Format	19
Table 6-8 – NACK Payload Format	19
Table 6-9 – NACK Reason Codes	19
Table 6-10 – Get Status Payload Format	19
Table 6-11 –Status Response Payload Format.....	19
Table 6-12 – Get Fault History Payload Format	20
Table 6-13 –Fault History Response Payload Format	21
Table 6-14 – Fault Codes.....	21
Table 6-15 – Set Compressor Payload Format.....	21
Table 6-16 – Set Coldhead Payload Format	21
Table 6-17 – Reset Payload Format	22
Table 6-18 – Get Version Payload Format	22
Table 6-19 –Version Response Payload Format	22
Table 7-1: Trouble Shooting Procedures	23
Table 7-2: M250 Fuse Listing	24
Table 7-3: M350 Fuse Listing	24



1 Revision History

Date	Revision	ECR #	Description of Change
November 2015	A	2714	Initial Release
December 2015	B	2714	Rebranding, formatting updates, updated sections 2.3, 4.1.2, 5.2.3 and Figure 13
May 2016	C	2909	Various updates for CE compliance, Table 4-6 addition, Table 7-2 content changed, removed section 8.6 and changed content of section 8.5. Added Figure 3 in section 5.2.3 Figure 18 image changed
April 2017	D	2909	Add M350 references Pg. ii: email address change Add Table 7-3 Removed section 6.3.7.1 and moved content to 6.3.7
May 2017	E	2909	Add 1020 compatibility to Table 2-1 Revise Table 4-2 , Table 4-3 , Table 4-5 , Figure 14 and Figure 15
August 2017	F	3044	Add Section 6.3.6 , add paragraph to section 8.3 , add step to section 8.3.2
October 2019	G	3142	Added notes to section 2.4 , 4.2 , 5.2.4.2 , and 6.2 ; modified Table 4-4
Document Part Number: 97-00056-000			

2 Preface

2.1 About Trillium US Inc.

Trillium US Inc., an Oregon based company, specializes in the manufacture and repair of cryogenic vacuum pumps, cryocoolers (refrigerators) and helium compressors for semiconductor, optical coating, linear accelerators, medical equipment, and R&D applications.

You can find just what you need from our range of products and support services:

- New Equipment - cryopumps, compressors, cryocoolers, and cryopump controllers such as the Model 250 / Model 350 Helium Compressors described in this manual.
- Comprehensive range of accessories for the installation of whole systems and a complete range of spare parts to repair cryopumps and compressors.

2.2 Other Services from Trillium US Inc.

Trillium US Inc. offers comprehensive refurbishment services for its own equipment as well as for that of most of our competitors. Our products and services are available through our global network of agents and dealers.

- Repair and refurbishment services - We offer our own quality products, as well as most other manufactures models, often with off-the-shelf availability.
- Exchanges - We offer our own quality products, as well as most makes of cryopumps and helium compressors, which are refurbished and fully warranted.
- Technical Support - Our support engineers will help determine if your cryopump system is operating correctly so that you can get your system back to optimum efficiency as soon as possible.
 - To contact Trillium US Inc. Technical Support:
 - E-mail: support@trilliumus.com
 - Telephone: 1-512-441-9258 or Toll Free: 1-800-404-1055
- Installation - On-site installation services are available to guarantee performance and save you time.
- Training - We offer on-site training to help you and your staff to know more about your cryopump and compressor systems. Our training will give you confidence and the ability to maintain a highest possible uptime for your system.

2.3 About this Manual

The purpose of this manual is to provide our customers using the Model 250 / Model 350 Helium Compressor with the information needed to safely and efficiently operate the compressor when operating as part of a cryogenic refrigeration system. Such a system is often comprised of the following equipment:

- Model 250 / Model 350 helium compressor unit
- Coldhead(s) or cryopump(s)
- Connecting helium lines

This manual describes the design, operation and maintenance of the Model 250 / Model 350 helium compressor unit.

2.4 Compatibility

Trillium US Inc. Model 250 / Model 350 Helium Compressors are compatible with various cold heads and cryopumps described in **Table 2-1** and **Table 2-2**. Each Model 250 / Model 350 compressor unit can be used to run one or more such cryopumps or cold heads. For other combinations than listed below, please contact Trillium US Inc. Technical Support using the contact information found in Section **2.2**.



Table 2-1: Model 250 / Model 350 Helium Compressor Coldhead Compatibility

Drive Unit Electrical Circuit Configuration	Cold Head Model (Manufacturer)	Number of Multiple Cold Heads Allowed
Model 250: RC	350CS (TUI)	1
	350CP (CTI)	1
Model 350: Scott "T"	350CS (TUI)	2
	350CP (CTI)	2
	1020CS (TUI)	1
	1020CP (CTI)	1

Table 2-2: Model 250 / Model 350 Helium Compressor Cryopump Compatibility

Drive Unit Electrical Circuit Configuration	Cold Head Model (Manufacturer)	Number of Multiple Cold Heads Allowed
Model 250: RC	CP8/CP8LP (TUI)	1
	CT8/CT8F (CTI)	1
Model 250: RC On-Board	OB-8/OB-8F (CTI)	1
Model 350: Scott "T"	CP8/CP8LP (TUI)	2
	CT8/CT8F (CTI)	2
	CP10 (TUI)	1
	CT10 (CTI)	1
Model 350: Scott "T" On-Board	OB-8/OB-8F (CTI)	2
	OB-10 (CTI)	1

Additional accessories will be needed to operate multiple cryopumps or cold heads. Refer to Section 4.3 for the part numbers and ordering information.

Note: The use of multiple coldheads and/or extended length helium supply lines may result in an increase to the Supply Side Running Pressure above the allowable limit; see Table 4-4, Section 5.2.4.2, and Section 6.2 for details.

3 Safety Warnings

3.1 Standards for the Use of Warnings and Cautions

Warnings are noted when there is a possibility of injury or death to persons operating the equipment or performing specific tasks or procedures noted in this manual. Cautions are noted when there is a possibility of damage to equipment if the caution is ignored.

3.2 Warnings Applicable to All Aspects of M250/M350 Operation

3.2.1 High Voltage and Electrical Shock Warnings



This unit can start automatically, and via remote control. Potentially fatal voltages are present in the compressor unit. The compressor should be switched off and disconnected from its power supply before carrying out any troubleshooting or maintenance activities on the unit.



Connect or disconnect the flex lines joining the compressor and its load (cryopump, coldhead, etc) only after the compressor and its load are switched off and separated from the power source. Otherwise,



electrical shock hazards may exist, potentially causing damage to the compressor unit, its load, or the operator.



Always provide proper grounding to the compressor unit and its load. All electrical power connection and disconnection of the unit should be done by a qualified electrician.



High voltage is present within the compressor unit and can cause severe injury from electrical shock. Permit only qualified electrical technicians to open the compressor enclosure to perform electrical troubleshooting.



The main power plug is used as the overall disconnect device. Ensure that access to the disconnect device is made available at all times.



The covers must be secured in place before powering up or operation; exposed electrical devices are accessible with the covers removed.

3.2.2 High Pressure Related Warnings



High gas pressure is present within the system and may cause severe injury if a safe pressure level is exceeded.



Do not charge the compressor without using a pressure regulator. Do not charge the compressor to a pressure level that exceeds limit set by the manufacturer.



The static pressure of a compressor is predetermined by the manufacturer based on operational safety and performance considerations. Do not exceed this level when charging a compressor.

3.2.3 Helium Gas-Related Warnings



Helium gas can cause rapid asphyxiation and death if released in a confined and un-ventilated area.



Use a pressure reducing regulator when withdrawing helium gas from a high-pressure gas cylinder.



Detaching the helium flex lines when the compressor load is at low temperature may cause the pressure to rise in the system beyond the permissible level therefore creating a safety hazard.

3.2.4 Heat-Related Warnings



97-000



The compressor motor may become hot during operation. Wait for the motor to cool down before working inside the compressor.

3.3 Operator Instructions

Follow standard Model 250 / Model 350 Helium Compressor operating procedures as described in this manual. If you still have questions regarding the safe operation of the Model 250 / Model 350 Helium Compressor, please contact Trillium US Inc. Technical Support using the contact information found in Section 2.2.



If the equipment is used in any manner not specified by the manufacturer, the protection provided by the equipment may be impaired.



Maintenance personnel must verify safe state of equipment after all repairs.

4 Introduction

4.1 General Information about the Model 250 / Model 350 Compressor

Trillium US Inc. offers industry-proven compressors such as the Model 250 / Model 350 Helium Compressor described in this manual, at highly competitive prices, and with flexible configurations. Model 250 / Model 350 compressors are available in water cooled with a low-voltage single phase power configuration; Model 350 compressors are available in water cooled with a low-voltage three phase power configuration.

4.1.1 Model 250 / Model 350 Features

The Model 250 / Model 350 Helium Compressor is designed for tens of thousands of hours of continuous operation. The main features of the Model 250 / Model 350 Helium Compressor are:

- Minimal maintenance requirements
- Rack mounting option, which is ideal for vacuum coating/ion implanters, semiconductor vacuum systems, CAT scanners, MRI systems and sputtering system applications
- Reliable helium and oil management system
- Front-mounted high pressure gauge
- Multi-drive digital electronics allowing independent control of the compressor and its load.

4.1.2 Overview of Model 250 / Model 350 Compressor Design & Operation

Model 250 / Model 350 Helium Compressor is designed to run different cryopump or coldhead models from different manufacturers (see **Table 2-1** and **Table 2-2** for compatibility information), for low-voltage and 60/50 Hz single phase or three-phase operations.

The compressor itself consists of four main components:

- Compressor capsule
- Heat exchanger with water ports
- Oil mist (vapor) separator
- Adsorber

The compressor unit and the coldhead are connected by way of helium gas flex lines. The compressor unit, coldhead, and helium lines are fitted with self-sealing couplings, and are charged with ultra high-purity (99.999%) helium gas (He 5.0 UH).



Helium gas is pumped through the compressor motor and after being compressed to a higher pressure, the oil is mixed with the helium. The oil acts (in addition to the primary function as a lubricator) as the medium to remove heat created by compressing the helium gas from the compressor motor. Once exiting the compressor motor, the hot oil/hot helium mixture is pumped via differential pressure out of the capsule through the water-cooler or air-cooled heat exchanger. The cooled oil then enters the oil mist separator, the vast majority of cool oil and cool helium are separated, such that each medium (helium and oil) enters leaves the oil mist separator through different parallel paths.

The heat exchanger removes the heat generated from the process of compressing helium in the capsule. The cooled oil returns to the capsule to lubricate and cool the capsule.

The volume tank is an empty tank that provides additional helium gas volume on the low pressure side of the compressor system. This prevents the low-side pressure from going too low when the compressor is running.

The helium gas purifying occurs after the heat removal and cooling process. Helium gas purification must occur because the helium out of the heat exchanger still has a small amount of oil vapor mixed with it. If this helium gas gets to the cryopump with oil vapor in it, the oil will freeze and contaminate the cryopump. The function of the oil mist (vapor) separator is to rid the helium gas stream of this oil vapor. Any oil condensate is then returned to the capsule.

Typically, the helium gas still contains a trace amount of oil vapor at this point. The adsorber then filters out the remaining oil vapor from the helium gas stream. Over time, the adsorber will become saturated with the oil vapor. Thus, it is important that the adsorber be replaced according to the recommended replacement interval found in section 8.3.

4.1.3 Description of Subsystems

Along with the four main components, **Table 4-1** describes the subsystems that serve to monitor the operating condition of the compressor unit and to ensure its safe operation.

Table 4-1: Description of Model 250 / Model 350 Helium Compressor Subsystems

Subsystem Name	Function
Phase rotation monitor	Purpose: Monitors the phase of the input power. Will not allow operation if the phase is incorrect.
Internal line break motor protector	An internal line break motor protector, located in the center of the Y of the motor windings, disconnects all three phases in case of an overload condition. The internal protector protects against single phasing
Overload relay	Purpose: Monitors system current. Will turn off the compressor if the current level exceeds the pre-set value
Thermal switch (TS1)	Purpose: Monitors helium temperature upstream of the heat exchanger. Safety Function: Will turn off the compressor if the helium temperature gets above 230°F (110°C)
Thermal Switch (TS2)	Purpose: Monitors oil temperature downstream of the heat exchanger. Safety Function: Will turn off the compressor if the oil temperature gets above 140°F (60°C)
Unloading valve	Purpose and Safety Function: Equalizes pressure within the compressor unit upon power interruption
Oil check valve	Purpose and Safety Function: Prevents oil migration when power is off
Fuses: Fuses for the main input power Fuses for 24VAC Out put	Safety Function: Over-current protection See Table 7-2 for fuse details
Internal relief valve	Purpose and Safety Function: Opens a shunt between the high and low-pressure helium gas circuits. Sets the proper operating pressure for the system regardless of the load.

Subsystem Name	Function
	Safety Function: If the differential pressure exceeds a preset value, this valve opens to allow safe operation.
External relief valve	Purpose and Safety Function: Opens the helium gas circuit to atmosphere if the helium gas pressure exceeds 350 PSIG (24.1 Bar)

4.1.4 Operational Flow

The flow diagrams for the Model 250 / Model 350 Helium Compressors are illustrated in **Figure 12**.

The work flow of helium gas within the compressor follows these steps:

1. High-pressure helium gas is delivered from the compressor to the coldhead through the "Supply" helium flex line at 250-260 PSI.
2. The helium gas is then compressed during the compression stroke of the cryopump.
3. The cryopump then expands the helium gas to expand during its expansion stroke. During this cycle of compression and expansion of the cryopump, the helium gas is forced through regeneration materials to increase the thermodynamic efficiency of the cycle.
4. With each successive cycle, the regeneration material becomes colder and colder.
5. Eventually, the cryopump temperatures come down to cryogenic range.
6. After expansion, the helium gas returns to the compressor through the "Return" helium flex line at 50-100 PSI to begin the cycle again.

4.2 Specifications

The Model 250 / Model 350 Helium Compressor specifications are listed in **Table 4-2** and **Table 4-3**.

Table 4-2: Power Requirements for Model 250 / Model 350 Compressor

Model	Rated Operating Voltage (VAC)	Working Voltage Range (VAC)	Frequency (Hz)	Phase	Max Current Draw (A)	Max Power (kW)*
M250 Low Voltage (single phase)	200-220	180-242	50	1	18	3.2
	208-230	187-253	60	1	18	3.3
M350 Low Voltage (three phase)	200-220	180-220	50	3	12	3.6
	208-230	180-253	60	3	12	3.9

*Nominal Power Factor = 0.85

Table 4-3: Model 250 / Model 350 Helium Compressor Specifications

Feature/Component	Specification Description
Physical Dimensions	See Figure 13
Weight	Water-cooled: 260 lbs. (118 kg)
Helium Pressure	See Table 4-4
Interface	Cold Head Power: MS3102A18-19S Remote Connector: TE 3-1634224-2 Helium connections: 1/2 inch male Aeroquip couplings.
Facility Requirements	Electrical Service Breaker: 25 Amp minimum (M250-Single Phase)/20 Amp minimum (M350-Three Phase) <i>(The end user shall size the branch circuit over current protective device to protect the equipment. This equipment does not have a primary protective branch over current device.</i> Maximum Fault current to the system should not exceed 5000 amps.
Adsorber Replacement Schedule	15,000 Hours (per elapsed time meter on the compressor) or 2 years, whichever comes first (see Section 8.3)

Feature/Component	Specification Description
Cooling Water (for water-cooled models)	.3 to .8 GPM (1.13- 3.03 liters/min) flow rate; 60°F - 80°F (15.5 - 26.7°C) maximum inlet water temperature, See Figure 3 . Recommended chiller capacity: .68 ton/per unit minimum. Water line connector: 3/8 inch Swagelok Tube Fittings (metric adapters available)
Ambient Air	40°F - 104°F (5°C - 40°C)

Table 4-4: Model 250 / Model 350 Helium Pressure Requirements

Model	Static Charge (PSIG)	Static Charge (Bar)	Fixed Operating Pressure Differential (PSIG)	Fixed Operating Pressure Differential (Bar)	Maximum Supply Side Running Pressure (PSIG)	Maximum Supply Side Running Pressure (Bar)
M250	240 ± 10	16.5±.68	200 ± 10	13.8 ± 0.69	300	20.68
M350	240 ± 10	16.5±.68	200 ± 10	13.8 ± 0.69	300	20.68

Note: The use of multiple coldheads and/or extended length helium supply lines may result in an increase to the Supply Side Running Pressure above the allowable limit, see Sections 5.2.4.2, and 6.2 for details. If pressure adjustments for a specific system configuration are required, the actual system Static Charge Pressure may be out of the range listed in the table.

4.3 Ordering Information

Table 4-5 and Table 4-6 contain ordering information for the Model 250 / Model 350 compressor units and optional accessories.

Table 4-5: Model 250 / Model 350 Helium Compressor Ordering Information

Compressor Configuration	Part Number
COMP, M250, SINGLE PHASE, LOW VOLT, WATER COOLED, MULTI-DRIVE	91-00250-000
COMP, M350, THREE PHASE, LOW VOLT, WATER COOLED, MULTI-DRIVE	91-00350-000

Table 4-6: Model 250 / Model 350 Optional Accessories and Replacement Parts

Accessories/Replacement Parts	Part Number
Adsorber	80-00253-000
Helium charge line (10ft.*), adapter 1/4" female Aeroquip to 1/4" flare	10346
Helium regulator	HR-580
Helium lines (10ft.*)	10418-10
Helium tee, for connecting two cryopumps	T-MMF
Splitter box, supplies power to up to three cryopumps	10359
Onboard splitter box, supplies power to up to three Onboard cryopumps	10366
Maintenance manifold, for helium clean-up process on compressors and cryopumps	10134
Cryopump drive cable (10ft.*), sends power to the cryopump motor from the compressor (onboard 10 pin to standard 3 pin)	10355-10
On-Board drive cable (10ft.*), sends power to the On-Board Cryopump motor from the compressor	81-00005-006
Cryopump patch cable (3"), (onboard 10 pin to standard 6 pin)	81-00053-002
Tool Kit, Running Purge Decontamination, Swagelok Ends (see Figure 19)	99-00074-000

Accessories/Replacement Parts	Part Number
Tool Kit, Running Purge Decontamination, 1/4" Male Aeroquip Ends (see Figure 20)	99-00074-001
Shipping Platform and Crate: Water	47-00099-000 47-00100-001
KIT, WATER FITTINGS, METRIC ADAPTER (see Figure 21)	99-00250-000

*Custom length available.

5 Installation

5.1 Safety Warnings

Review the safety warnings in Section 3 before beginning any installation activities.

5.2 Installation Steps

5.2.1 Unpacking and Inspection

Once the equipment is received, inspect the exterior of the shipping carton for any signs of damage. Report any damage and file a claim with the shipping company immediately.

In addition, at least two “Tip-n-Tell” or “TiltWatch” labels are mounted on the exterior of the shipping carton. Inspect these labels carefully before accepting the shipment. Any sign that the package has been mishandled during transit may indicate that the compressor may be damaged due to oil migration within the system. This could cause the unit to overheat and ultimately fail after a short period of operation. The compressor must be returned to the factory for service. Report the mishandling of the package and file a damage claim with the shipping company immediately. Failure to do so will void the warranty on the compressor. Please also contact Trillium US Inc. Technical Support using the contact information found in Section 2.2.

Remove the straps and packaging materials from the compressor container, then lift or roll the unit out of the container carefully. Inspect the exterior, if any damage is observed, inform the shipping company and Trillium US Inc. **Keep the original packaging materials in case the unit needs to be returned to the factory for service.**

Most shipping companies have a certain grace period for reporting damages due to shipping in order to process the insurance information in a timely manner. Therefore it is highly recommended that the shipping container be opened and the unit inspected immediately whether or not it will be put into operation right away. Tip and Tells are present on the external packaging as well on the compressor interior as shown in **Figure 1** and **Figure 2**.

Caution: **When transporting or storing the compressor unit, make certain it is not tilted by more than 45 degrees from horizontal level to avoid potential oil migration damage to the compressor.**

Figure 1 – Model 250 / Model 350 Compressor Internal Tip &Tells

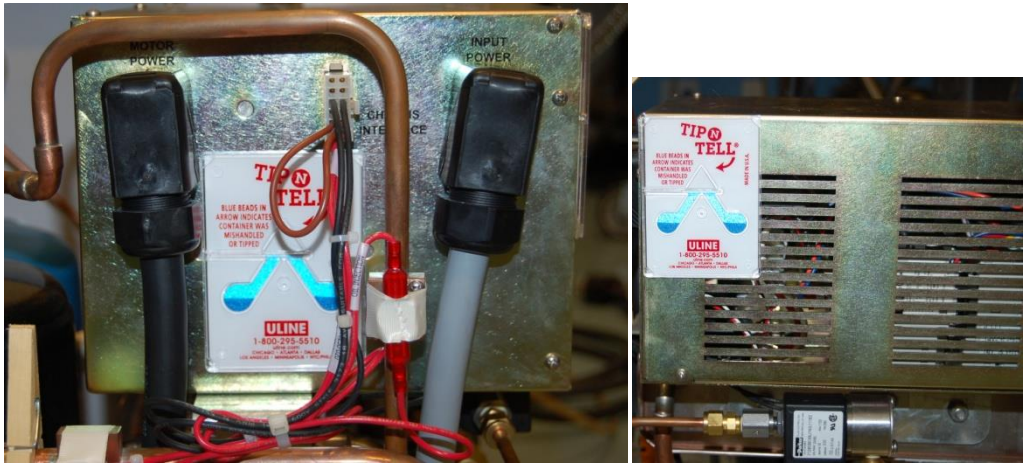

Figure 2 – Model 250 / Model 350 Packaging Tip &Tells



5.2.2 Mounting the Compressor

It is highly recommended that the compressor unit be installed on a level and steady surface.

If the unit must be installed in a tilted manner, the maximum tilting angle is 10 degrees. Tilting the unit more than this maximum allowable angle could result in damage and contamination in the system, and may void the warranty on the unit.

Power cable and plumbing connections must be protected from damage. Do not route plumbing across controls.

5.2.3 Preparing the Compressor for Operation

1. Check the voltage of the power source before connecting the main power cable to a suitable connector or disconnect box, making sure that the compressor switch is off.
 - a. If the frequency of the power source is different from the factory default setting (see **Table 4-2**) it may be necessary to change the frequency via the switch on the front panel
2. For water-cooled Model 250 / Model 350 units, connect the cooling water:
 - a. Typical municipal drinking water is acceptable, however, a closed loop chilled water source is recommended.



- b. Minimum water flow rate of 0.3 - 0.8 GPM (1.13 – 3.03 liters/min) is required to achieve a maximum discharge temperature of 100°F (38°C). The inlet water temperature should not exceed 80°F (26.7°C). See **Figure 3** for the required water flow rate vs. water inlet temperature.
- 3. Verify that helium pressure is between 240± 5 PSIG (16.5 ± .35 Bar). If the pressure is low, refer to Section 5.2.4.2 for charging procedures.
- 4. Start the compressor and run for about 15 minutes to stabilize the compressor oil inventory.
- 5. The compressor is now ready to be connected to the cryopump(s) or coldhead(s).

Figure 3 – M250/M350 Recommended Minimum Water Flow Rate vs. Water Inlet Temperature

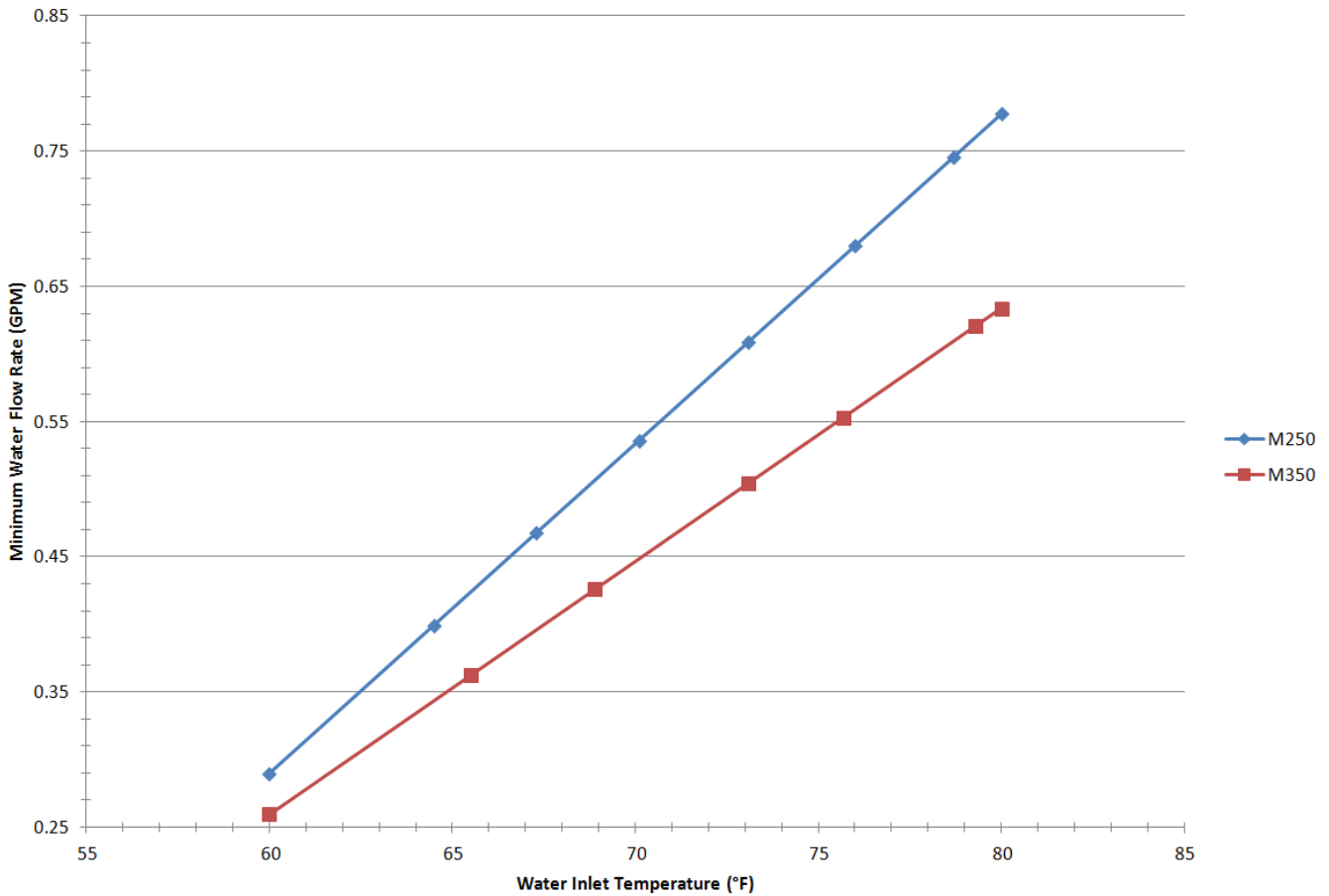

5.2.4 Installation

5.2.4.1 Ambient Conditions and Coolant Connection

Ambient Conditions:

When the compressor is in operation, the ambient temperature should be between 40°F - 104°F (5°C - 40°C). The compressor unit should be set up in a non-condensing environment. An optimal location would be in a well ventilated (or temperature controlled) location.

Coolant Connection:

Caution: For water-cooled compressor models, the water used in the unit operation must meet the specifications indicated in Table 4-3.



Caution: Failure to comply with the coolant specifications may result in serious damage to the compressor and may void the warranty on the unit.

Identify the inlet and outlet connection ports first before connecting the hoses. The water supply line should be connected to the inlet port on the compressor.

An in-line water particulate filter is recommended to prevent heat exchanger fouling.

Periodically check the coolant flow rate and temperature to ensure the proper operation of the compressor unit.

5.2.4.2 Verifying and/or Refilling Compressor with Helium Gas

Caution: All safety regulations related to handling pressurized gas cylinders must be observed. Only use helium with 99.999% or better purity (He 5.0 UH) when performing refill operation.

The compressor should already be pressurized to 240 ± 5 PSIG ($16.5 \pm .35$ Bar) upon arrival. However, in the event that the Static Charge Pressure is too low or too high, steps shall be taken to restore the compressor to the proper helium pressure levels. Examples of situations when the compressor may have lost some pressure include lost pressure due to connecting/disconnecting helium flex lines, or after certain maintenance/clean-up procedure.

Therefore, prior to each operation of the compressor, verify that the helium pressure inside the compressor is at the proper levels as stated in **Table 4-3**. If the pressure is outside of the required limits, follow the appropriate steps below:

Static Charge Pressure should also be checked after the compressor has been connected to the overall system (as instructed in Section **5.2.4.3**), as the static pressure may change based on the overall system pressure after connection. Further checks should be performed on the running system (See **Section 6.2**) to ensure that the Supply Side Running Pressure has not exceeded the maximum allowable limits from **Table 4-4**; in this case the pressure adjustments should be made with the compressor/system running.

If the helium pressure is too high:

1. Remove the protective cap from the "Fill/Vent" fitting.
2. Slowly connect the female charge fitting. As the connector is tightened, helium pressure will bleed out of the compressor.
3. Continue to bleed out helium gas until the pressure reaches the desired limits defined in **Table 4-3**. Once the pressure is reached, disconnect the Aeroquip.
4. Re-install the protective cap.

If the helium pressure is too low:

1. Connect a pressure regulator rated at 400 PSIG (27.6 Bar) delivery pressure and a helium charge line to a user-supplied helium supply gas cylinder. Terminate the charge line with the female charge fitting.
2. Set the helium pressure regulator to 10-25 PSIG (.69 - 1.7 Bar). Loosen the $\frac{1}{4}$ " flare connector (part of the female charge fitting, in between the helium charge line and the $\frac{1}{4}$ " female Aeroquip adaptor).
3. Allow helium gas to flow through the flex line for a minimum 30 seconds to purge the charge line of air. Tighten the flare connector while venting. After tightening, close the valve on the pressure regulator.
4. Remove the Aeroquip cap of the helium fill/vent fitting on the front of the compressor.
5. Tighten female charge fitting on the end of the helium charge line to the gas fill/vent Aeroquip fitting of the compressor.
6. Set the pressure regulator to approximately 270 PSIG (18.6 Bar) and slowly open the valve on the pressure regulator. When the helium supply pressure gauge reaches the specified limits found in 5, tightly close the regulator valve.
7. Ensure the regulator valve is tightly closed. Shut off the helium pressure regulator on the helium bottle.
8. Remove the female charge fitting and reinstall the Aeroquip cap onto the compressor.



Caution: If the compressor pressure drops over a period of time, either when not in operation or without the lines being connected/disconnected, this may be an indication that there is a leak along the helium circuit (i.e. compressor, lines or coldhead/cryopump). If that is the case, do not just keep refilling the system with helium gas. Such leaks will introduce ambient air/moisture and cause contamination in the helium stream. This will result in catastrophic failure of the whole cryogenic system if not properly addressed. Contact and report the leak to Trillium US Inc. immediately using the contact information found in Section 2.2.

5.2.4.3 Connecting the Helium Flex Lines

Caution: Connect or disconnect the helium flex lines only when the power to the compressor unit is switched off. Never twist or kink the helium flex lines during the installation process.

Before connecting the helium flex lines, follow these steps:

1. Identify the helium "Return" (low pressure) and "Supply" (high pressure) ports on the compressor front panel.
2. Clearly mark the helium flex line that will be used to connect to the corresponding "Supply" and "Return" port on the cryopump or coldhead.

Note: The helium flex lines are equipped with self-sealing couplings which can be connected or disconnected without helium escaping.

Follow these steps to connect the helium flex lines:

1. Unscrew the protective caps from the couplings and keep the caps for future use.
2. Check the couplings for cleanness. When necessary, use lint-free clean cloth or soft brush to clean the couplings.
3. Check the self-sealing connector flat rubber gasket to make sure that it is clean and properly positioned. Replace any missing or defective seals.
4. Use only the open-wrenches supplied with the installation kit or equivalent wrenches. For a ½" coupling, tighten with a 1-3/16" wrench and stabilize with a 1" wrench.
5. Make the initial turns by hand and then use the wrenches until the fittings bottom out. **This is critical, improper or loose connections will affect compressor function.**
 - a. Effective connections can be validated by confirming the leak rate is less than 1×10^{-5} mBar -l/sec

If the flex lines need to be bent to a radius less than 8" (20 cm), then a 90° helium elbow needs to be installed. Contact Trillium US Inc. using the contact information found in Section 2.2.

Some installations may require different accessories to be installed in line with the helium flex lines. To connect these accessories, follow the instructions listed above and any other applicable user manual associated with the accessory.

5.2.5 Electrical Connection

Caution: Before connecting power to the compressor unit, make sure the factory setting of the operating voltage matches that of the power supply where the unit is being installed. Failure to do so will result in performance degradation of the system.

Ensure the frequency switch on the front panel is set appropriately for the location of use.

6 Operation

6.1 Before Switching ON the System

After the compressor unit and its load (cryopump, coldhead, etc) are installed and connected, check the helium gas pressure as indicated by the pressure gauges mounted on the front panel of the compressor unit. Refer to Section 4.2 for the proper static pressure readings for the compressor.



If the helium pressure needs to be adjusted, refer to Section 5.2.4.2 for procedures to adjust the helium pressure inside of the compressor.

6.2 Normal Operation

The load of the compressor can be powered through the power connectors located on the front panel of the compressor. To start operation of the compressor, do the following:

1. Open the coolant supply (water-cooled compressor model only)
2. Switch on the main power source.
3. Press the green ON button to start the compressor. Both the compressor and its load should start simultaneously

Note: During initial start-up, the compressor internal relief valve may begin to “Chatter”. This is a normal occurrence and should subside within a few minutes.

During operation, check the operating pressure frequently. Refer to **Table 4-3** for required operating pressures. If necessary, stop the compressor and adjust the helium pressure (see Section 5.2.4.2). If pressure drop-off occurs frequently, a substantial leak may be in the helium circuit. In this case, stop operation and contact Trillium US Inc. customer service immediately (see Section 2.2).

Note: In operation the use of multiple coldheads and/or extended length helium lines may impact the compressor’s Supply Side Running Pressure due to the increased system charge volume. This pressure increase could result in the compressor overheating and shutting down. While the compressor is running, check the Supply Side Pressure Gauge, if the Supply Side Running Pressure is above the values specified in Table 4-4, use the instructions in Section 5.2.4.2 to reduce the pressure (THE COMPRESSOR MUST REMAIN RUNNING WHILE THE PRESSURE IS BEING REDUCED). Document the resultant adjusted Static Charge Pressure for the system in this configuration for future reference (the compressor must be turned off to check the Static Charge Pressure). Depending on the specific equipment configuration, the adjusted Static Charge Pressure may be out of range for those values listed in Table 4-4.

Note: During shut down, the compressor motor may reverse rotate as the pressures equalize internally through the scroll members of the motor. This will cause the compressor to emit a “shuttering” sound. This reversal of direction has no effect on the compressor durability and is entirely normal.

4. To shut down the compressor unit, press the red OFF button on the front panel for digital electrical boxes or the main power switch for analog electrical boxes. For water cooled units, allow coolant to continue to circulate for at least 10 more minutes before shutting off flow.

6.2.1 Cycle Times

There is no set answer to how often the cryogenic compressor can be started and stopped in an hour. Trillium US Inc. recommends a maximum of twelve cycles per hour. One critical consideration is a minimum run time required to return oil to the compressor after start up. To assure proper oil return, one minute is the minimum run time for all cryogenic compressors. A second consideration is a four minute minimum off cycle time once the compressor cycles off.

6.3 Electronics Interface Connections

The Model 250 / Model 350 helium compressors are provided with a pig tail for connecting to the installation location.

Electrical box interfaces are described below

6.3.1 Remote Interface

The electrical box can be controlled through a remote interface. This allows a PLC or other hardware device to control and monitor certain functions of the compressor and cold-head.

The electrical box provides a D-sub 25 pin connector for remote interface control and status collection; the pin-out is shown in **Table 6-1**.



Table 6-1: J3 Remote Connector (25 Pin D-Sub)

PIN #	SIGNAL DESCRIPTION
1	N/C
2	N/C
3	Reset
4	Cold Head ON/OFF
5	N/C
6	Compressor ON/OFF
7	N/C
8	N/C
9	N/C
10	N/C
11	N/C
12	N/C
13	N/C
14	N/C
15	N/C
16	Pressure Alarm
17	Phase Error
18	Temperature Alarm
19	Run Status
20	N/C
21	N/C
22	N/C
23	N/C
24	Ground
25	+24V Output

6.3.2 D-Sub User Controls

The Model 250 / Model 350 compressors remote interface inputs are shown **Table 6-2**. The inputs require a dry-contact switch or an opto-coupler as shown in **Figure 4**. Short each input (pin 3, 4, or 6) to the Input Return (pin 24) to assert the signal. Open the circuit to de-assert the signal.

Since there are up to three ways to issue commands in the electrical boxes; front panel buttons, USB interface, and the DB25 interface, the control logic uses a “last command” approach based on state transitions. The transition of shorting an input to pin 24 signals the controller to turn on the corresponding subsystem. The transition of removing the short to pin 24 signals the controller to turn off the subsystem. If the remote system intends to turn on a subsystem and the input is already shorted to pin 24, then the short must be removed for 100ms or more and then the short reapplied. If the remote system wants to turn off a subsystem and the input is already open, the pin must be shorted to pin 24 for 100ms or more and then opened again.

Example: To start the compressor connect pin 6 to pin 24. To start the coldhead, connect pin 4 to pin 24.



Figure 4 – User Control Signal Interface

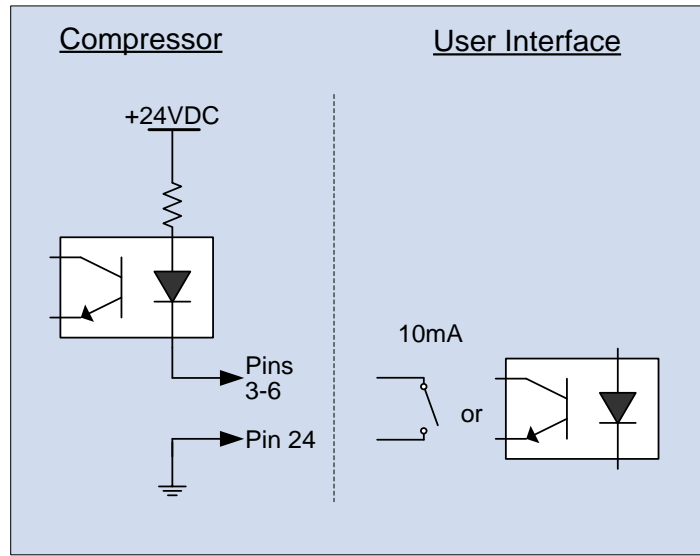

Table 6-2: Remote Interface Inputs

SIGNAL	SIGNAL DESCRIPTION
Reset	Short pin 3 to pin 24 for 3 seconds or longer to reset the control board processor. Leave pin 3 open-circuit (floating) for normal operation.
Coldhead Enable	Short pin 4 to pin 24 to turn on the coldhead. Open-circuit pin 4 to turn off the coldhead.
Compressor Enable	Short pin 6 to pin 24 to turn on the compressor. Open-circuit pin 6 to turn off the compressor.

6.3.3 D-Sub User Status

The Model 250 / Model 350 compressors remote interface outputs are shown in **Table 6-3**. The output signals are designed to drive a user-side opto-coupler as shown in **Figure 5**. Each output is shorted to ground by the controller when the output is asserted and is open-circuit otherwise. Connect a 24VDC load between each output pin and the Output Source (+24V power) at pin 25. Each output should draw a maximum of 5 milliamps. The outputs can be used to drive LEDs or opto-couplers.

Example: Use the output voltage from pin 19 & 25 to monitor the run status of the compressor, this output can be used to drive a LED or used as an input to a PLC.

Figure 5 – User Status Signal Interface

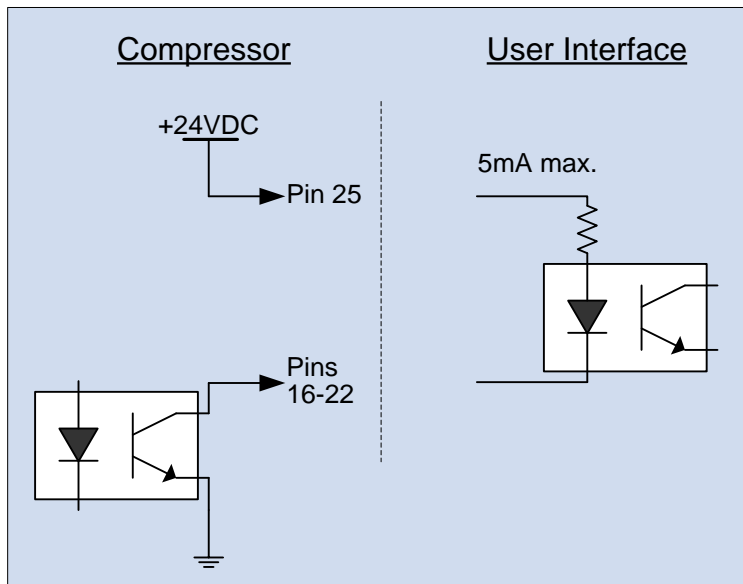

Table 6-3: Remote Interface Outputs

SIGNAL	SIGNAL DESCRIPTION
Pressure Alarm	When the compressor pressure is too low, pin 16 is shorted to ground. Pin 16 is left floating when the pressure is normal or the system is off.
Phase Error	When there is input power phase error, pin 17 is shorted to ground. Pin 17 is left floating when there is not a phase error.
Temperature Alarm	When the compressor is too hot, pin 18 is shorted to ground. Pin 18 is left floating when the compressor temperature is normal.
Run Status	When the compressor, the coldhead, or both are running, pin 19 is shorted to ground. When the compressor and coldhead are both off, pin 19 is left floating.

6.3.4 Compressor Front Panel User Interface

The Model 250 / Model 350 compressors have a digital electrical box. On start-up the front panel LCD will display its initialization sequence and once complete the system status screen will be displayed showing the current state of the compressor and cold head as well as the current accumulated compressor run time

Note: If the phases are not connected properly, an "AC Power Phase Error" will be displayed. The compressor cannot be started until the unit is powered down and the phase error is corrected.

These configurations of the compressor provide 4 buttons and a 2-line display for easy operation:

- **Off:** Pressing this button will turn the Cold Head, Compressor, and Solenoid Valves off. Pressing the Off button will always override the signals on the Remote Interface allowing the user to turn off the system.
- **On:** Pressing this button will turn the Solenoid Valves, Compressor, and Cold Head on unless prohibited by one or more fault interlocks.
- **Menu:** Pressing this button will cycle between the Status Screen and the Active Faults Screen. Pressing this button when the Fault History screen is displayed will move to the Status Screen. If more than one fault is active, the Menu button is used to cycle through each of the active faults before going back to the Status Screen.
- **History:** From either the Status Screen or Active Faults Screen, pressing this button take will take the user to the Fault History screen where the most recent fault will be displayed. Pressing the History button will cycle through

each of the logged faults in reverse-chronological order until the last logged fault is displayed. Then the fault history will wrap around to the most recent fault again.

6.3.5 Compressor Operational Checks

Table 6-4 lists all of the compressor operational checks and the cause of a failed operational check.

Table 6-4: Operational Checks

System Interlock	Fault
Helium Pressure Alarm*	Pressure alarm contact is not OPEN. Verify pressure contact and helium pressure.
Helium Temperature Alarm	Temperature alarm contact is not CLOSED. Verify temperature contact and helium temperature.
Oil Return Temperature Alarm	Temperature alarm contact is not CLOSED. Verify temperature contact and oil temperature.
Overload Alarm	Contactors overload tripped. Reset overload on contactor.

*Pressure switch does not come with standard models.

6.3.5.1 Compressor Front Panel Fault Errors

The Model 250 / Model 350 compressors that have the following errors that can be displayed:

- System Error
- Compressor Overload
- Low Pressure
- High Temperature
- AC Power Phase Error
- F13-F15 Fuse Blown
- F16-F18 Fuse Blown

6.3.6 Compressor Maintenance Warning

For the Model 250 / Model 350 compressors the front panel LCD will display “Change Adsorber” at an elapsed time of 15,000 hours (since last reset). Temporary access to alternate screens can be gained via the Menu button. Once the adsorber has been replaced the maintenance timer can be reset by pressing and holding the Menu and History buttons together for 5 seconds.

6.3.7 Compressor System Shut Down

Manual shut-down

Push the OFF button or the Main Power Switch

Automatic shut-down

The following system indication will cause the compressor to automatically shut down:

1. Low Helium pressure
2. High Helium pressure (not standard)
3. High Helium temperature
4. High Oil Return temperature
5. Contactor Overload
6. Loss of Power

If an automatic shut down occurs, refer to **Table 6-4** to identify and remove the fault. Once the fault has been corrected, the user can restart the system by pressing the “ON” button

6.3.8 USB Interface (J1-Maintenance)

The Model 250 / Model 350 compressors have a USB type B connector provided. This connector provides control input and status output using USB protocol. The underlying protocol of the USB link is HID. The data is streamed as raw bytes.

6.3.9 Communications via USB

Communication via USB can be achieved via PC integration. The format for the packet is shown in **Table 6-5**

Table 6-5: USB Packet Format

Field	Bytes	Range	Notes
Header #1	1	0x55	
Header #2	1	0xAA	
Packet Length	2	[0:102]	Number of bytes in: <ul style="list-style-type: none"> • Source • Destination • Command • Payload Data Field is transmitted in <i>little endian</i> .
Command	1	[0:255]	See
Payload Data	Various	Various	See Table 6-7 thru Table 6-19 Payload fields that are native types (e.g. integers) and have more than one byte are sent in <i>little endian</i> .
CRC	1	[0:255]	The packet's CRC is calculated by: <ul style="list-style-type: none"> • Seed value = 0 • Polynomial = $x^8 + x^2 + x + 1$ • Includes the following fields: <ul style="list-style-type: none"> ○ Payload Data Length ○ Source ○ Destination ○ Command ○ Payload Data

Table 6-6: USB Maintenance Interface Command ID's

Name	Packet ID	Description
Get Status	229	Requests the system status
Status Response	10	Packet contains system status information
Get Fault History	53	Requests the set of historic faults
Fault History Response	54	List of either current or historic faults
Set Compressor	57	Commands the compressor to be on/off
Set Coldhead	58	Commands the cold/head to be on/off
Reset	224	Forces the control board processor to reset
Get Version	226	Request for the firmware version information
Version Response	225	Packet contains the version, build date, and part number

Name	Packet ID	Description
ACK	254	Response to indicate a command was executed successfully
NACK	255	Response to indicate a command failed to execute successfully

6.3.9.1 USB Payload Formats

Table 6-7 thru Table 6-19 define the payload formats for all commands listed in Table 6-6.

Table 6-7: ACK Payload Format

Response to: Any command that successfully executes and does not have a specific response.		
Field	Bytes	Range/Units
Response to Command ID	1	See
Payload Length	1	

Table 6-8 – NACK Payload Format

Response to: Any command that fails to execute correctly or whose format is incorrect.		
Field	Bytes	Range/Units
Command ID	1	See
Reason Code	1	See Table 6-9
Payload Length	2	

Table 6-9 – NACK Reason Codes

Value	Description
0	Unspecified/Other
1	Unrecognized/unsupported command
2	CRC error
3	Parameter out of range or other invalid data
4	Not ready for command
5	Packet length error
6	Timeout

Table 6-10 – Get Status Payload Format

Response Expected: Status Response		
Action: Queries the Pump Controller for its current status.		
Field	Bytes	Range/Units
Payload Length	0	No payload data

Table 6-11 –Status Response Payload Format

In Response To: Get Status		
Action: Payload contains the Pump Controller status.		
Field	Bytes	Range/Units
Compressor Run Time	4	Seconds
PCB Temperature	2	0.1 C
24V Input Voltage	2	mV
Digital Output States	2	Bit Set: Bit 0 – Compressor Pressure Fault Bit 1 – Compressor Temperature Fault Bit 2 – Phase Error Fault Bit 3 – System Running Bit 4 – Fan/Heater On Bit 5 – Compressor/Solenoid On Bit 6 – Coldhead On Bit 7 – Spare Output #1 On Bit 8 – Spare Output #2 On Bit 9-15 - Reserved
Digital Input States	2	Bit Set: Bit 0 – Coldhead Enable Bit 1 – Compressor/Solenoid Enable Bit 2- System Reset Bit 3 – Compressor Pressure Fault Bit 4 – Compressor Temperature Fault Bit 5 – Compressor Overload Fault Bit 6 – Spare Remote Input #1 Bit 7 – Spare Remote Input #2 Bit 8 – Spare Chassis Input #1 Bit 9-15 - Reserved
Button States	2	Bit Set: Bit 0 – On Button Pressed Bit 1 – Off Button Pressed Bit 2 – Menu Button Pressed Bit 3 – History Button Pressed Bit 4-15 – Reserved
Fault States	2	Bit Set: Bit 0 – System Fault Bit 1 – AC 220V Fuse Blown Bit 2 – AC 24V Fuse Blown Bit 3 – Compressor Overload Fault Bit 4 – AC Phase Fault Bit 5 – Compressor Pressure Fault Bit 6 – Compressor Temperature Fault Bit 7 – 3 Phases Detected; 1 Phase Expected Bit 8 – 1 Phase Detected; 3 Phases Expected Bit 9-15 - Reserved
Payload Length	16	

Table 6-12 – Get Fault History Payload Format

Response Expected: Fault History Response



Action: Queries the Pump Controller for the list of historic faults.		
Field	Bytes	Range/Units
Payload Length	0	No payload data

Table 6-13 –Fault History Response Payload Format

In Response To: Get Fault History		
Action: Payload contains the list of historic faults.		
Field	Bytes	Range/Units
Number of Faults	1	[0..25]
Reserved	1	N/A
<i>The remaining payload is a sequence of <u>Number of Fault</u> entries:</i>		
Fault Identifier	1	See Table 6-14
Timestamp	4	Running time, in seconds, of the compressor at which the fault occurred.
Payload Length	[2..102]	

Table 6-14 – Fault Codes

Value	Description
0	System Fault
1	AC 220V Fuse Blown
2	AC 24V Fuse Blown
3	Compressor Overload
4	AC Phase Fault
5	Compressor Pressure Fault
6	Compressor Temperature Fault
7	3 Phases detected; 1 Phase expected
8	1 Phase detected; 3 Phases expected

Table 6-15 – Set Compressor Payload Format

Response Expected: ACK/NACK		
Action: Powers the Compressor/Solenoid on or off.		
Field	Bytes	Range/Units
Power State	1	0 – Off 1 - On
Payload Length	1	No payload data

Table 6-16 – Set Coldhead Payload Format

Response Expected: ACK/NACK

Action: Powers the Coldhead on or off.		
Field	Bytes	Range/Units
Power State	1	0 – Off 1 - On
Payload Length	1	No payload data

Table 6-17 – Reset Payload Format

Response Expected: ACK/NACK		
Action: Performs a reset on the control board processor.		
Field	Bytes	Range/Units
Payload Length	1	No payload data

Table 6-18 – Get Version Payload Format

Response Expected: Version Response		
Action: Queries the control board for the set of firmware version numbers.		
Field	Bytes	Range/Units
Payload Length	0	No payload data

Table 6-19 –Version Response Payload Format

In Response To: Get Version		
Action: Payload contains the list of firmware version numbers.		
Field	Bytes	Range/Units
Communication Protocol Version	2	[1..255]; currently set to 1
Year code was compiled	2	Full year (yyyy)
Month code was compiled	1	Month (1=Jan; 12=Dec)
Day code was compiled	1	Day of Month
Firmware Part Number	2	Will be 437.
Firmware Version Number	2	
Bootloader Part Number	2	Will be 436.
Bootloader Version Number	2	
Hardware Part Number	2	Will be 401.
Calculated Checksum	2	Should be equivalent to Stored Checksum
Stored Checksum	2	Should be equivalent to Calculated Checksum
Reserved	5	
Payload Length	25	

7 Troubleshooting

7.1 Troubleshooting Activities

Table 7-1 describes some problems that users might encounter while operating the Model 250 / Model 350 Helium Compressor and provides potential solutions to those problems. Additional Fault trees are presented in Figure 16 and Figure 17.

Table 7-2 and Table 7-3 list the fuse functions and amperage rating for the Model 250 / Model 350 Compressors. See Figure 18 for PCBA fuse locations.

If a compressor problem still persists after performing the corrective actions described in this section, please contact Trillium US Inc. Technical Support for further assistance (see Section 2.2).

Table 7-1: Trouble Shooting Procedures

Problem	Possible Cause	Corrective Action
The compressor On/Off switch (SW1) is in the On position but will not start.	<ol style="list-style-type: none"> 1. No power is coming from the power source. 2. Incorrect or disconnected wiring within the compressor 3. Thermal protection switch (TS1 and/or TS2) is open. 4. Pressure protection switch (PS1 or PS 2) is open* 5. High current has tripped the current overload relay. 	<ol style="list-style-type: none"> 1. Check service fuses, circuit breakers, and wiring associated with the power source. Repair as needed. 2. Check the compressor wiring against the wiring schematic. 3. Confirm that switch TS1 and/or TS2 is open. 4. Add Helium if the pressure is low, remove Helium if the pressure is high 5. Reset the current overload relay.
Compressor stops after several minutes of operation and remains off.	<ol style="list-style-type: none"> 1. High temperature of the compressor caused by insufficient cooling (most likely due to the ambient temperature being too high, resulting in the opening of thermal protection switches (TS1 and/or TS2). 2. Insufficient helium static pressure. 3. High temperature helium gas tripped the thermal protection switch (TS1). 4. Low power source voltage. 5. Mechanical seizure. 6. High Pressure in the system 	<ol style="list-style-type: none"> 1. Confirm that sufficient cooling air is flowing to the compressor. If possible, provide additional cooling to the surrounding environment. 2. Add helium, using the procedures described in Section 5.2.4.2. 3. Check for proper cooling of the compressor unit. 4. Confirm that power source voltage is correct. 5. Contact Trillium US Inc. for assistance. 6. Check for proper pressure in Table 4-4.

*High Pressure switch does not come with standard models.



Table 7-2: M250 Fuse Listing

Fuse Designator	91-00250-000 Function (single phase)	Amperage	TUI Part Number
PCBA: F13	Main Power to PCBA	8	31-00012-014
PCBA: F14	Main Power to PCBA	8	31-00012-014
PCBA: F15	Main Power to PCBA	8	31-00012-014
PCBA: F16	T1 Output-24VAC	5	31-00012-015
PCBA: F18	T1 Output-24VAC	5	31-00012-015
PCBA: F21	T2 Input	3	31-00012-017
PCBA: F22	T2 Input	3	31-00012-017
PCBA: F23	Populated but not used	3	31-00012-017

Table 7-3: M350 Fuse Listing

Fuse Designator	91-00250-001 Function (three phase)	Amperage	TUI Part Number
PCBA: F13	Main Power to PCBA	8	31-00012-014
PCBA: F14	Main Power to PCBA	8	31-00012-014
PCBA: F15	Main Power to PCBA	8	31-00012-014
PCBA: F16	T1 Output-24VAC	5	31-00012-015
PCBA: F18	T1 Output-24VAC	5	31-00012-015
PCBA: F21	T2-T3 Input	4	31-00012-013
PCBA: F22	T2-T3 Input	4	31-00012-013
PCBA: F23	T2-T3 Input	4	31-00012-013

8 Maintenance

8.1 Maintenance Personnel Requirements

Only trained and qualified personnel should perform the maintenance procedures described in this section. All other maintenance work must be performed by Trillium US Inc. personnel in the factory. Please contact Trillium US Inc. to make arrangement for such work. See contact information in Section 2.2.

8.2 Removing the Compressor from Service: Removal, Transport and Storage

It is recommended that the Model 250 / Model 350 compressor be removed from service when carrying out the maintenance duties described in Section 8.3.

To remove the compressor unit from service, do the following:

1. Turn off the compressor unit by pressing the OFF button
2. Switch off the main power supply to the compressor
3. Separate the compressor unit from the main power source
4. Allow coolant to continue circulate for at least 10 more minutes (for water-cooled Model).
5. Allow the compressor load (cryopump, coldhead, etc.) to warm up before detaching helium flex lines

Caution: Loosening or detaching helium flex lines with the compressor load at low temperature without proper warming-up can result in loss of helium and/or pressure rise in the cryopump or coldhead unit beyond its designed maximum pressure level.

When transporting the compressor unit, follow these guidelines:

1. Make sure the appropriate protective caps are properly secured before shipping.
2. Always store the compressor unit in a dry place.
3. If a freezing temperature environment is anticipated whether during shipping or under storage, make certain the coolant in the compressor circuit is properly drained.

Caution: The compressor unit should never be tilted more than 45 degrees either during shipping or in storage.

8.3 Scheduled Preventative Maintenance Activity

The only scheduled field service maintenance required on the Model 250 / Model 350 compressor is the replacement of compressor adsorber after every 15,000 hours of operation (as shown on the Elapsed Time Meter) or 2 years, whichever comes first. While in many cases an adsorber can last longer, Trillium US Inc. experience dictates that from a cost-value perspective it is better to swap the adsorber out after 2 years to protect the integrity of the overall integrated solution with the compressor load.

The adsorber is used as the final filter to keep the oil vapor out of the helium gas just before the gas is pumped into the compressor load (cryopump, coldhead, etc.). After about 15,000 hours of operation or 2 years, the effectiveness of the adsorber will decrease and need to be replaced. If not replaced, the oil particles could accumulate on the cold surface of the compressor load, reducing the cooling performance of the overall system. In severe cases of such oil contamination, the load could cease to function completely.

For the Model 250 / Model 350 compressors a 15,000 hour resettable maintenance timer is provided; once 15,000 hours has elapsed a "Change Adsorber" message is displayed on the LCD.

To remove and replace the compressor adsorber, follow the steps described in Sections **8.3.1** and **8.3.2**.

8.3.1 Remove the Compressor Adsorber

To remove the compressor adsorber:

1. Turn off the compressor and disconnect it from the main power supply.
2. Allow sufficient time for the load of the compressor (cryopump or coldhead) to warm up before detaching the helium flex lines from the compressor. Refer to Section **5.2.4.3** for proper procedures to detach helium flex lines.

Caution: Detaching helium flex lines with the compressor load at low temperature could result in loss of helium gas. It may also cause the pressure rise in the system beyond the permissible level therefore creating a safety hazard.

3. After detaching the helium flex line from the helium supply connection located on the adsorber panel on the front panel.

Caution: Detaching helium flex lines with the compressor load at low temperature (i.e. without proper warming-up) can result in loss of helium and/or pressure rise in the compressor unit beyond its designed maximum pressure level.

Note: Unscrew the two-self sealing coupling halves quickly to minimize minor gas leakage. See Figure 11 for an illustration of the self-sealing couplings.

4. Remove 1/4-20 Philips Screws (18) from the rear, side and top panels and remove cover panel as one piece. See Figure 6.



5. Use the two wrenches supplied with the (optional) Installation Kit to avoid loosening the body of the coupling from its adapter. Hold one wrench tight on the coupling half attached to the flex line coming from the OMS. Use the other wrench to loosen the coupling of the helium line attached to the adsorber. See **Figure 7**. Unscrew the two self-sealing coupling halves quickly to minimize minor gas leakage. **Figure 11** contains an illustration of the self-sealing couplings.
6. Unscrew and remove the nut and washer from the helium supply connector on the front panel. See **Figure 8**.
7. Remove the two screws that hold the adsorber to the bottom of the compressor chassis, see **Figure 9**.
8. Slightly pull the adsorber assembly towards the back of the compressor. Then tilt the unit outwards and lift the assembly out to remove it from the chassis, see **Figure 10**.
9. Save all nuts, bolts, and washers for installing the replacement adsorber.
10. The removed adsorber can be returned to Trillium US Inc. for credit. Section **2.2** provides the contact information.

Figure 6 – Removal of Cover Panels



Figure 7 – Adsorber Aeroquip OMS Supply Line Removal



Figure 8 – Adsorber Aeroquip Nut Removal



Figure 9 – Adsorber Chassis Screw Removal



Figure 10 – Adsorber Removal



Figure 11 – Self Sealing Connector

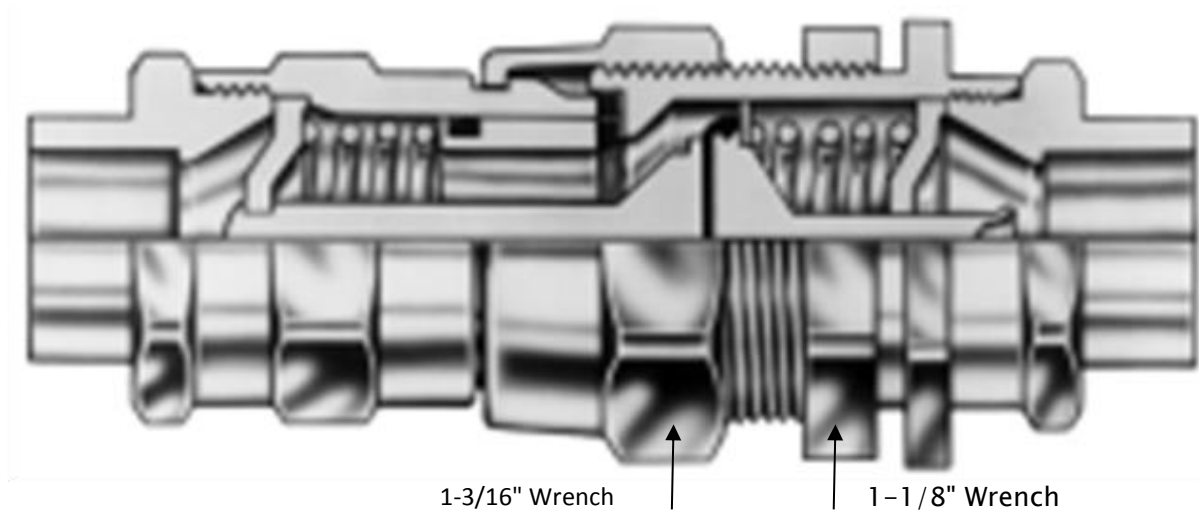

Note: Image from Aeroquip Catalog

8.3.2 Install Replacement Adsorber

To install the replacement adsorber:

1. Remove the dust caps from the self-sealing coupling halves at each end of the replacement adsorber.
2. Check the self-sealing connector flat rubber gasket to make sure that it is clean and properly positioned.
3. Place the adsorber back in the compressor using the nuts, bolts and washers set aside during the removal process described in Section 8.3.1.

4. Install the two-self sealing coupling halves quickly to minimize minor gas leakage.
5. Use the 1-1/8" and 1-3/16" wrenches, holding the 1-1/8" wrench tight on the coupling half attached to the adsorber. Use the 1-3/16" wrench to tighten the coupling to the helium supply/OMS line.
6. Make the initial turns by hand and then use the wrenches until the fittings bottom out. **This is critical, improper or loose connections will affect compressor function.**
 - a. Effective connections can be validated by confirming the leak rate is less than 1×10^{-5} mBar -l/sec
7. Make sure the supply pressure is in accordance to the pressures found in **Table 4-4**. If the pressure is either too high or too low, follow the instructions in Section **5.2.4.2** to add helium gas to the compressor.
8. Write the installation date and number of running hours (if known) on the decal provided with the replacement adsorber.
9. Re-install the cover panel that was removed in Section **8.3.1**.
10. Restart the compressor.
11. Re-set the maintenance timer, see Section **6.3.6** (if applicable).

8.4 *Unscheduled Corrective Maintenance*

The following corrective maintenance activities may be necessary should the helium gas circuit of Model 250 / Model 350 compressor becomes contaminated.

8.4.1 **Removing Helium Contamination**

Helium contamination is usually indicated by irregular, noisy, or intermittent operation (ratcheting), and sometimes the seizure of the coldhead or cryopump drive mechanism. This is caused by the accumulation of frozen contaminants within the compressor load and resulting in interference. The source of the helium contamination is due to either:

- Inadvertent introduction of ambient air into the system
 - Use of helium with purity of less than 99.999% (He 5.0 UH), such as helium gas used for leak detection and welding.
- Minor contamination can usually be removed by running the coldhead or cryopump for several hours to trap the contaminants in the coldhead/cryopump, then shutting down the compressor and immediately removing the helium lines at the compressor. Then allow for the coldhead/cryopump to warm thoroughly and perform the helium cleanup procedures as outlined in the coldhead/cryopump manual.
- Stubborn contamination involving water vapor requires decontamination of the compressor. One effective method involves supplying clean helium to the return side of the compressor at appropriate pressures while venting a small amount of gas from the supply side while the compressor is running. This is referred to as a "running purge." Contact Trillium US Inc. if such a procedure is needed.

The steps to remove compressor decontamination: (with the compressor running)

1. Set the helium regulator to whatever the compressor return pressure gauge reads (i.e. 50 PSIG)
2. Attach the helium charge line to the running purge fill fitting
3. Attach the running purge fill fitting to the return Aeroquip
4. Loosely attach the running purge vent fitting to the supply Aeroquip
5. Slowly tighten the running purge vent tool until helium is venting from the vent tool
6. Open the regulator valve and watch the compressor pressure gauge. The pressure should be stable at the pressure set in step 1. The adjustment of the regulator or the amount of helium venting from the compressor may need to be performed in order to maintain stability.
7. Once the pressure is stabilized, allow the running purge to continue for a minimum of 15 minutes.
8. After a minimum of 15 minutes, stop the running purge by first removing the running purge vent tool. Next, close the regulator valve and remove the helium charge line from the compressor.
9. Turn off the compressor.
10. Remove the running purge tools from the compressor.
11. Check the static pressure and readjust the pressure to the proper limits (see **Table 4-3**) in accordance with Section **5.2.4.2**.



8.5 Returning Equipment

Before returning any equipment, contact Trillium US Inc. to receive special instructions and to obtain a return authorization (RMA) number. See contact information in Section **2.2**.

Figure 12 – M250 / M350 Water Piping and Instrumentation Diagram

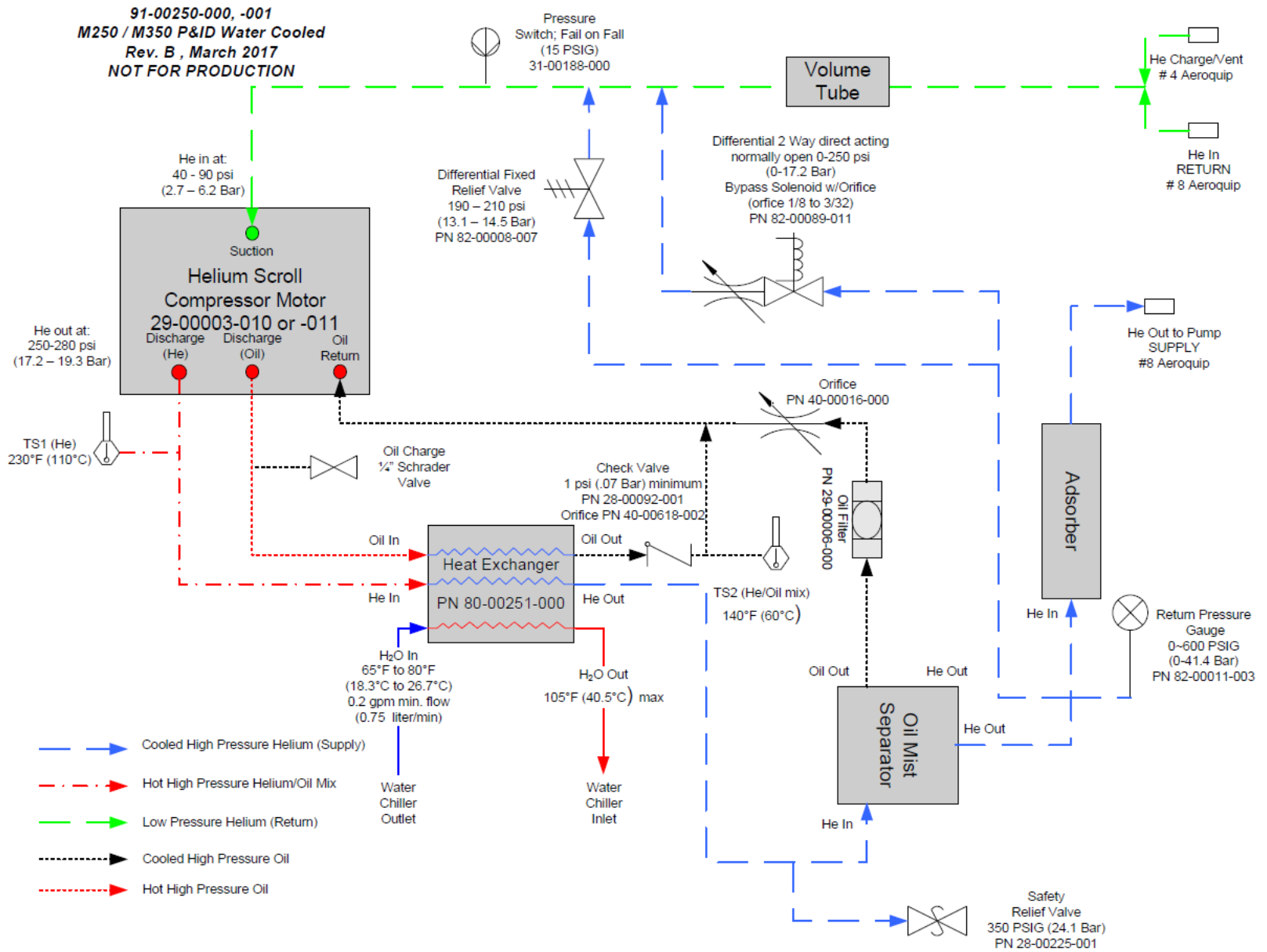
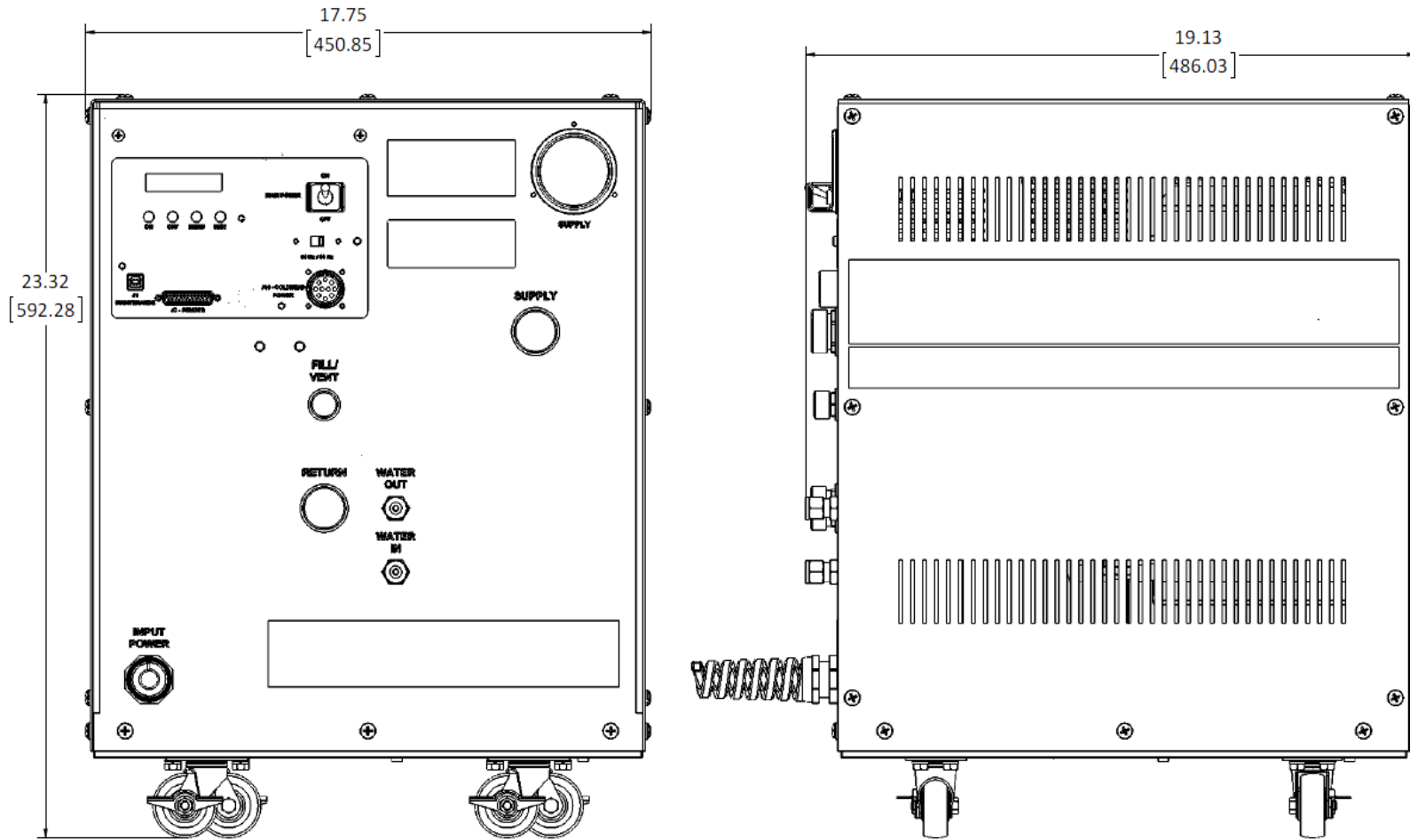

Figure 13 – M250 / M350 Water Cooled General Dimensions



OVERALL DIMENSIONS: in (mm)

Figure 14 – M250 Low Volt Single Phase Multi-Drive Schematic, 93-00300-001

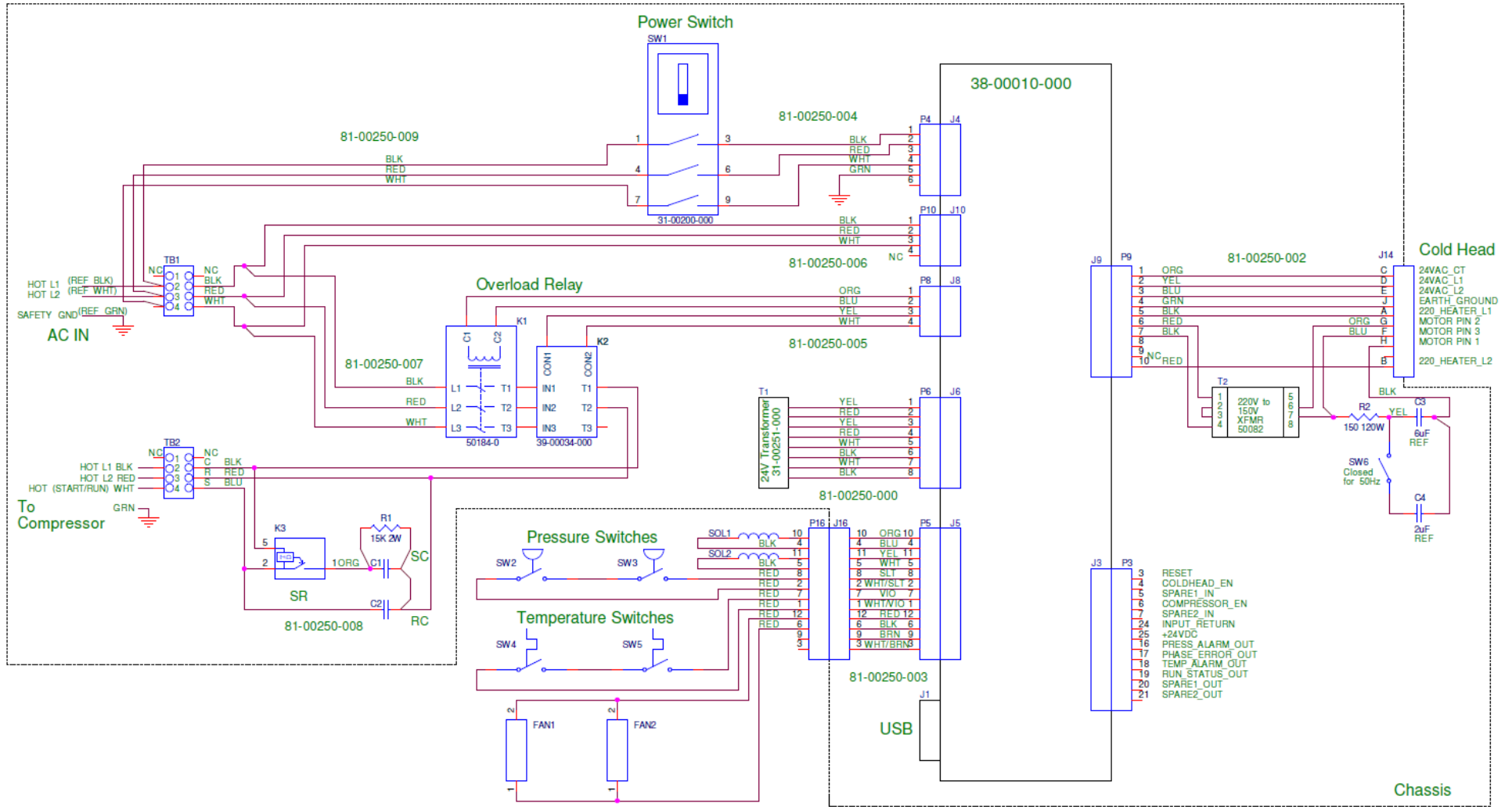

Figure 15 – M350 Low Volt Three Phase Multi-Drive Schematic, 93-00300-000

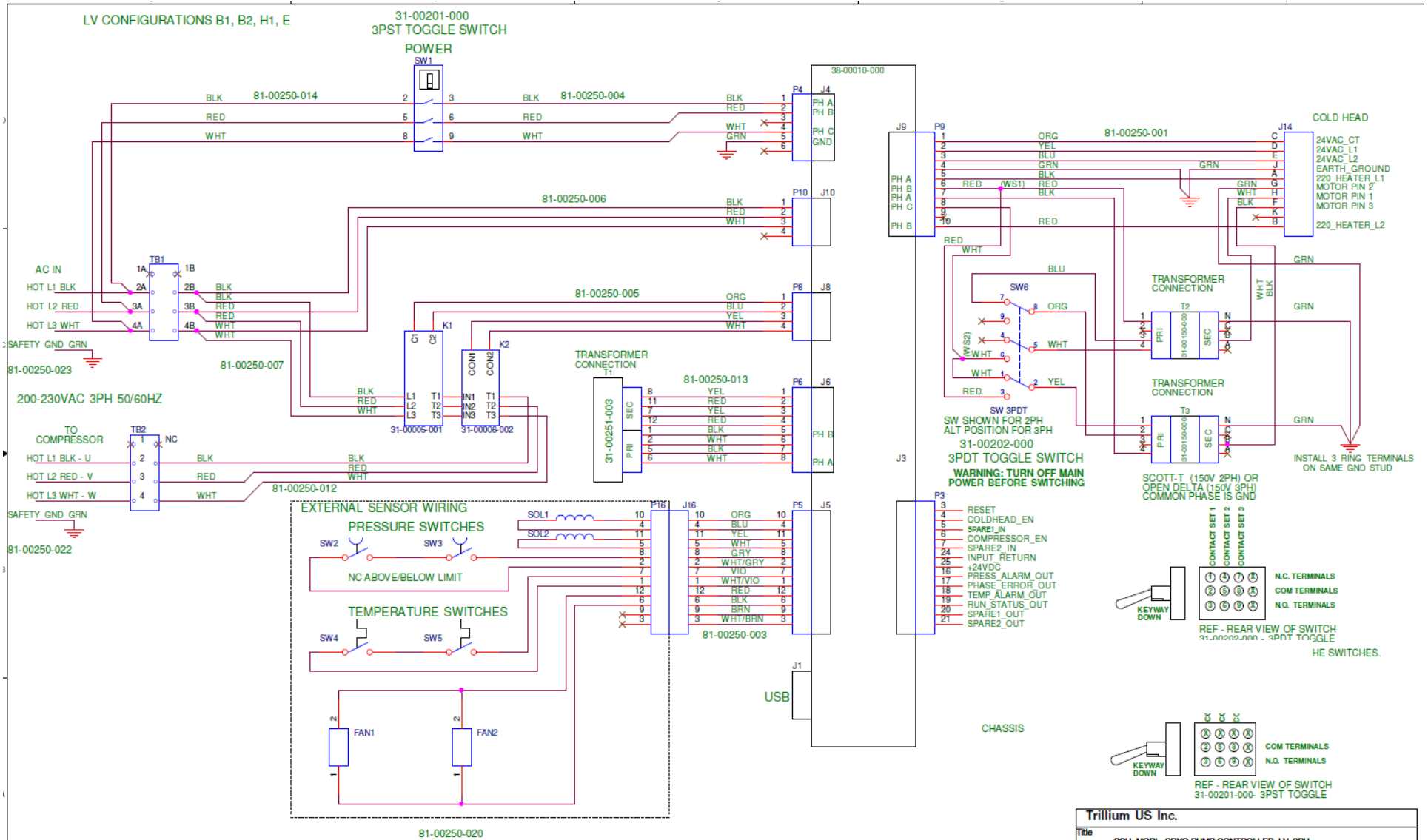

Figure 16 – M250/M350 Fault Tree: Compressor will Not Start / Adsorber Replacement



Monday, April 10, 2017

M250 / M350 Compressor Fault Tree

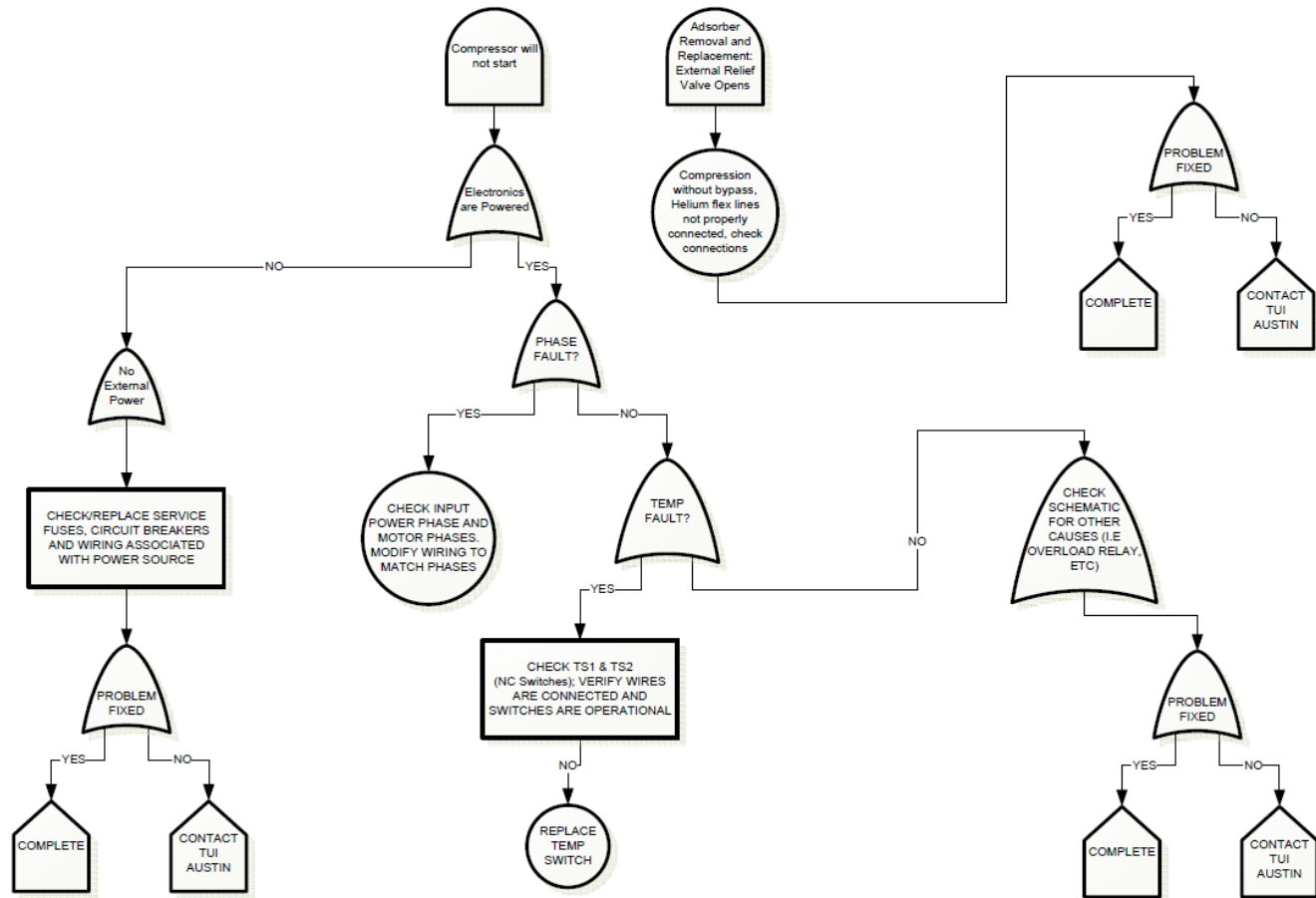

Figure 17 – M250/M350 Fault Tree: Compressor Starts but Shuts Off



Monday, April 10, 2017

M250 / M350 Compressor Fault Tree

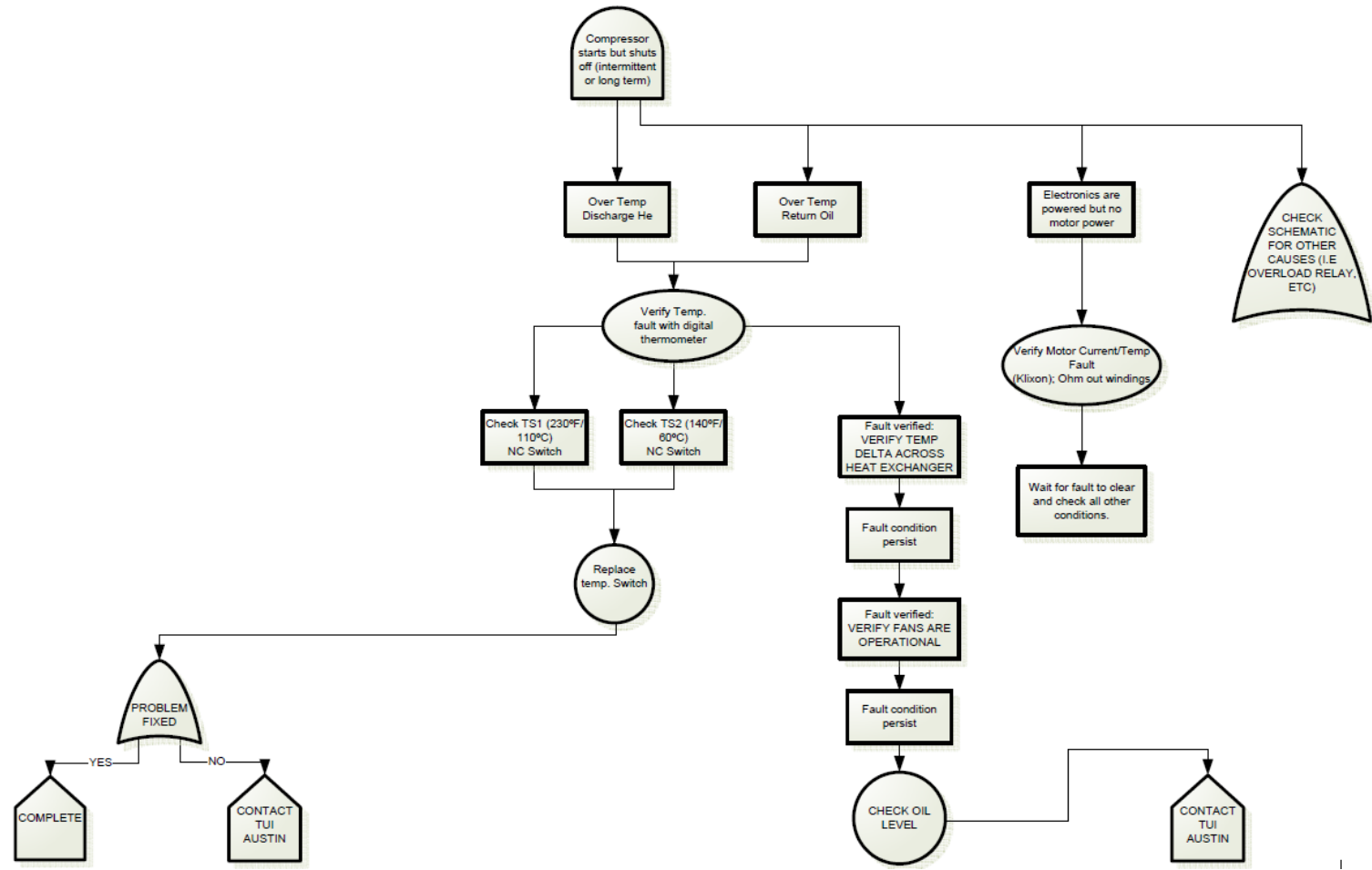
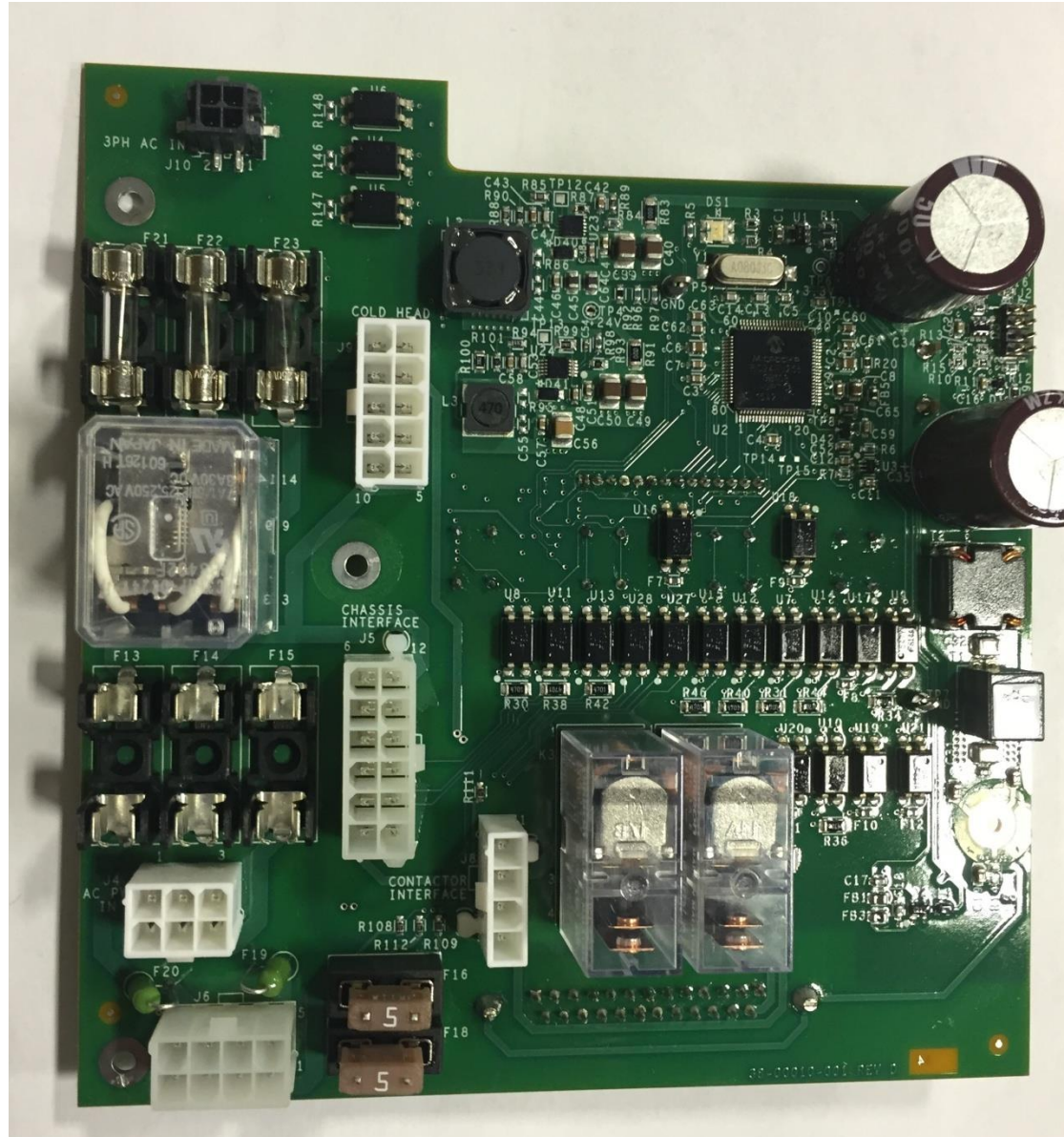

Figure 18 – M250/M350 Fuse Locations Multi-Drive



*F21, F22 and F23 are not present on all revisions of the PCBA

Figure 19 – 99-00074-000 Tool Kit Contents

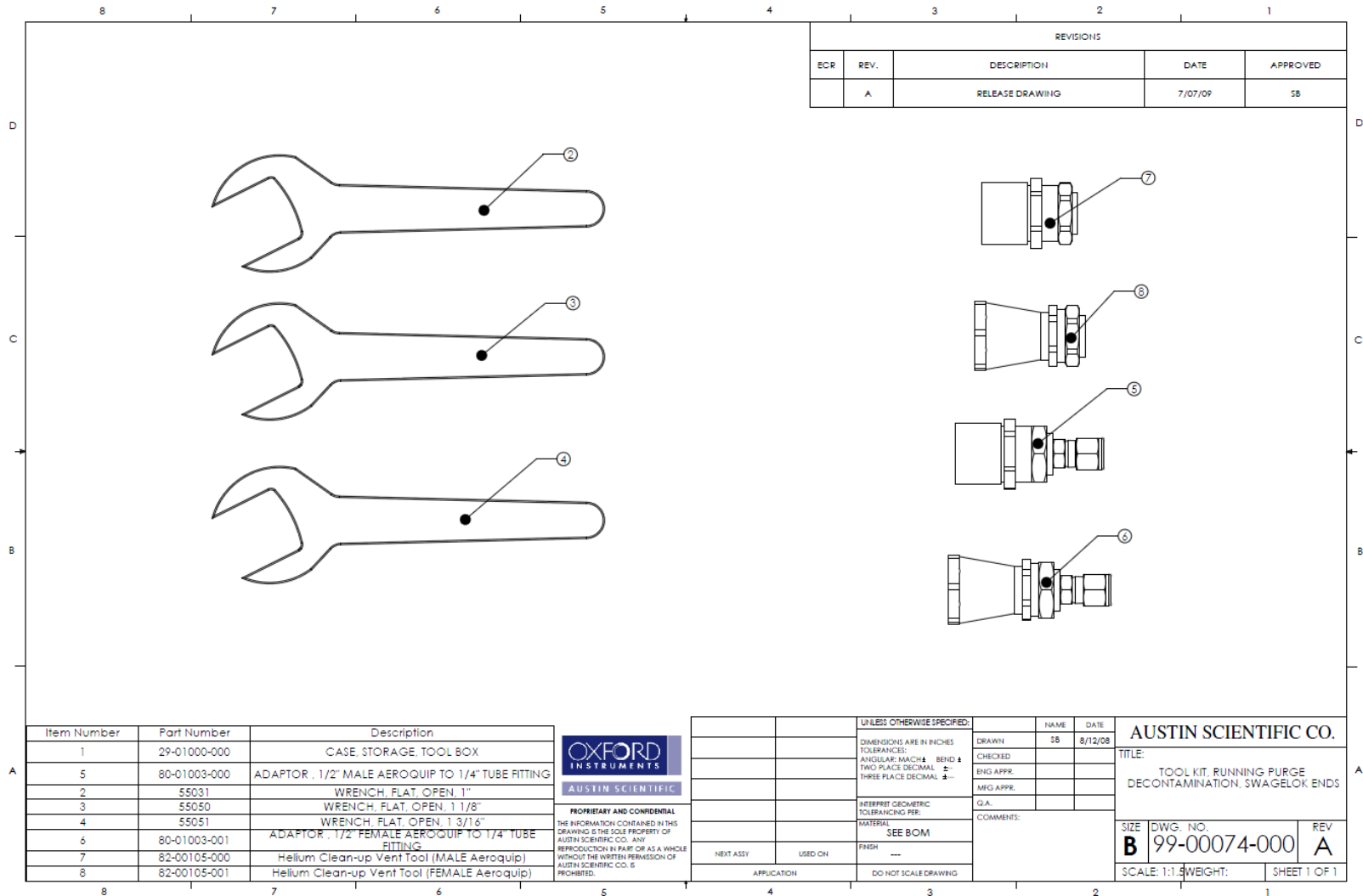

Figure 20 – 99-00074-001 Tool Kit Contents

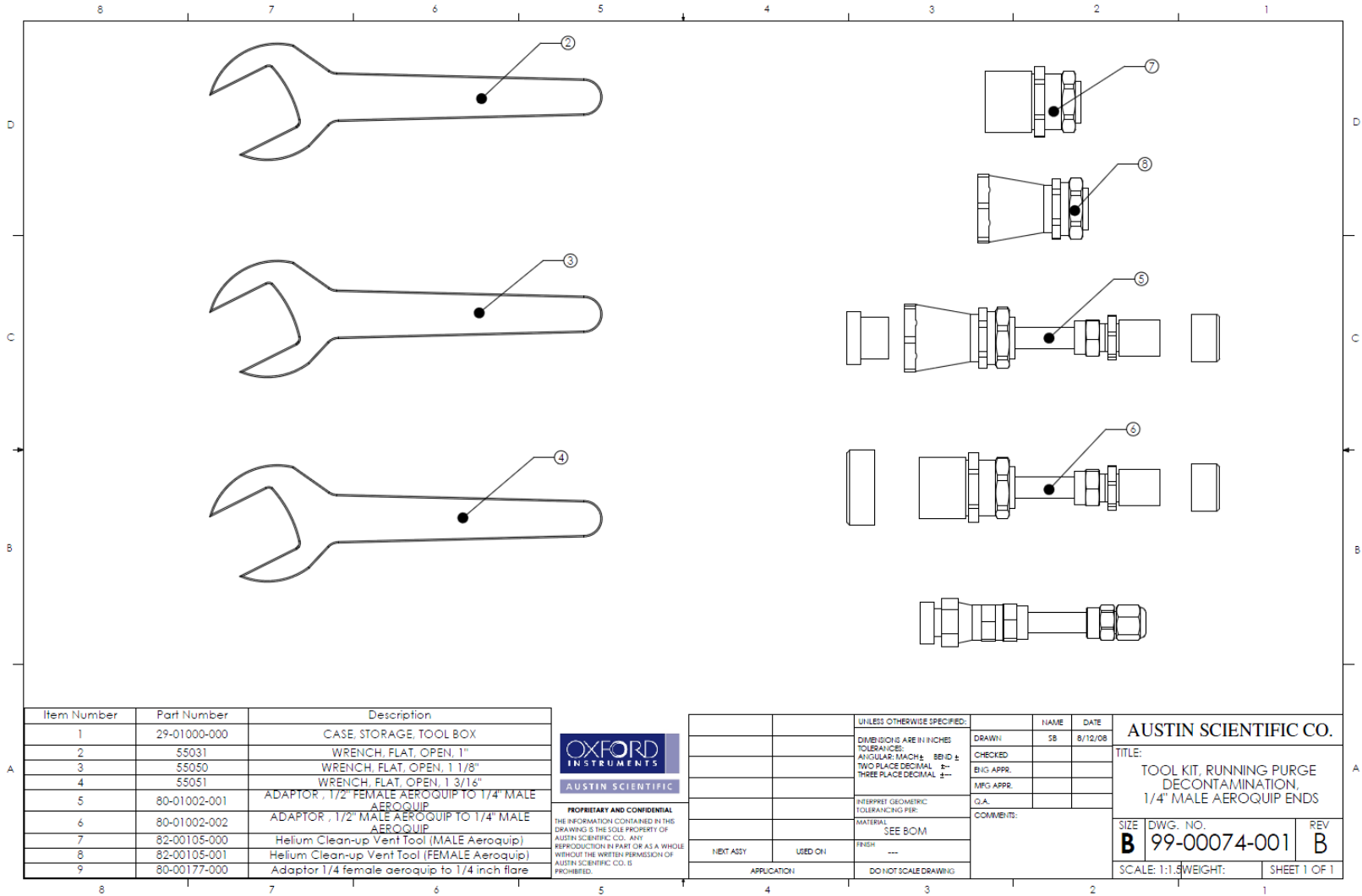
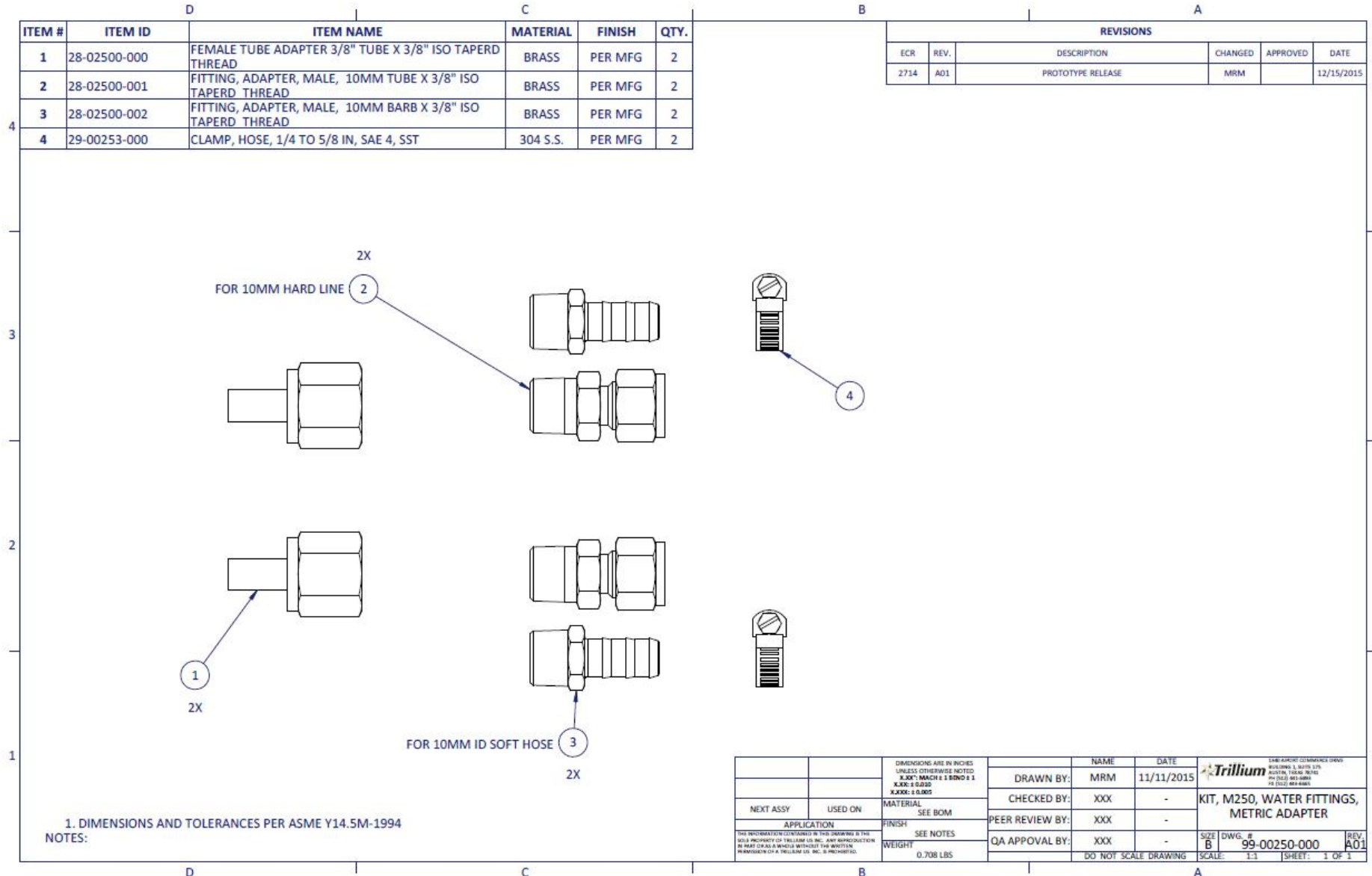

Figure 21 – 99-00250-000 Kit Contents



This Page Intentionally Left Blank